

# The Nature Conservancy Port Susan Bay Restoration Monitoring Plan

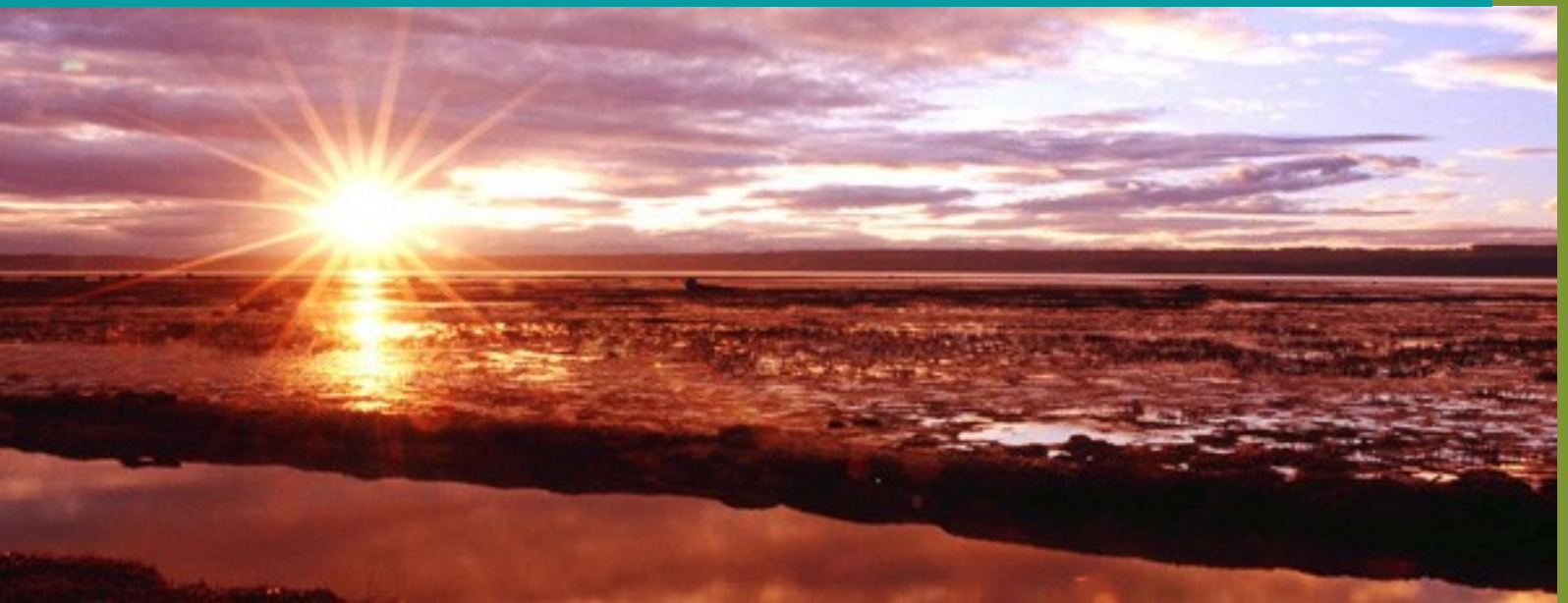

Isa Woo<sup>1</sup>, Roger Fuller<sup>2</sup>,  
Monica N. Iglecia<sup>1</sup>, Kelley L.  
Turner<sup>3</sup>, John Y. Takekawa<sup>1</sup>

<sup>1</sup> U.S. Geological Survey Western Ecological  
Research Center, 505 Azuar Drive, Vallejo, CA  
94592

<sup>2</sup> The Nature Conservancy, 410 N 4<sup>th</sup> Street, Mt.  
Vernon, WA 98273

<sup>3</sup> U.S. Geological Survey Western Ecological  
Research Center, Nisqually National Wildlife  
Refuge, 100 Brown Farm Rd, Olympia, WA  
98516



Please cite as:

Woo, I., R.Fuller, M. Iglecia, K. Turner, J. Takekawa. 2011. The Nature Conservancy: Port Susan Bay Estuary Restoration Monitoring Plan. Unpublished report to The Nature Conservancy. US Geological Survey, Western Ecological Research Center, 505 Azuar Drive Vallejo CA 94592. 115 pp.

Cover photo credit: The Nature Conservancy

## EXECUTIVE SUMMARY

- The Nature Conservancy (TNC) is planning to enhance over 1600 ha of wetlands in the Stillaguamish River estuary near Stanwood, Washington. The Port Susan Bay region supports some of the finest estuarine habitats in Puget Sound that are critical to an array of wildlife species including raptors, shorebirds, snow geese, several species of salmon, other fishes, and clams. The TNC Port Susan Bay Preserve encompasses much of the Stillaguamish River estuary, and TNC is initiating a restoration project to restore and reconnect over 160 ha of diked uplands. In addition to restoring habitat on the 60 ha footprint, this project will improve connectivity between the river and hundreds of hectares of tidal marshes west and north of the project. In this document, we provide a framework for monitoring the effects of the restoration efforts.
- The long-term vision of the Port Susan Bay conservation program is to restore a functional estuarine ecosystem that is resilient to ongoing threats and adaptable to climate change. The restoration will contribute to the common vision and shared strategy of learning, improving, and sharing to advance the science of estuarine restoration within Puget Sound. The primary Project Objectives include: 1) restore self-sustaining native tidal wetlands that support estuarine-dependent animals; 2) improve juvenile salmon access to restored rearing habitats, and 3) improve connectivity between the river and northern tidal habitats.
- We structured the monitoring of performance metrics in a stepwise fashion: the main drivers of the monitoring efforts are overarching restoration objectives, within each objective are detailed hypotheses, and specific predictive or conceptual models are listed. In addition, historical, pre-restoration, and initial site conditions provide insight to the area and can contribute to our understanding of restoration responses. Within these objectives are specific hypotheses that are addressed through the monitoring plan. We also present some of the key uncertainties and constraints for the restoration.
- Restoration monitoring has been described as the equivalent of accounting in finance. Understanding the results and learning from restoration actions requires measuring and presenting those results. The monitoring plan was developed with an underlying framework of a before-after, control-impact or BACI design. This design allows comparison of baseline (before) ecological conditions with those following restoration, as well as applying a control (reference site) and impact (restoration site) comparison to separate restoration effects from regional changes.
- The monitoring plan is focused at two nested scales, the restoration site and the entire estuary system. The nested approach is taken because the restoration site occurs at the mouth of the river and will affect system-scale processes such as the distribution of freshwater and sediment. To understand habitat changes at the site scale, a nearby reference marsh will be used for comparison. Monitoring methods were divided into categories of landscape, elevation, habitat, hydrology, sedimentation, and fauna that address restoration changes in ecosystem structure, processes, and function. These include specific methods that have been developed and employed for monitoring of several tidal marsh restoration projects. Specific details for many of the methods are included in the Appendices.
- The monitoring timeline includes intensive baseline and 5-year post-restoration sampling to allow for adaptive management, followed by periodic monitoring for 30 years which should encompass the primary period of change. However, ecological processes are highly variable, so the monitoring plan will be a “living” document that is subject to revision and improvement as the restoration progresses. Furthermore, the scale of monitoring will always be dependent on funding, and, while we make no specific monitoring commitments in the absence of funding, this document will guide the application of any funding obtained.

## DEFINITIONS

**BACI:** before-after, control-impact sampling design (Stewart-Oaten 1992)

**capacity:** the project's ability to produce/provide for specific wildlife function (i.e., the site's capacity to produce invertebrate prey resources for juvenile Chinook).

**conceptual model:** a representation of a real world natural system and its interconnected components, often in the form of diagrams

**controlling factor:** the basic physical and chemical conditions that construct and influence the structure of the ecosystem (e.g., salinity, temperature, hydrodynamics; Thom et al. 2004)

**DO:** dissolved oxygen

**ecosystem function:** the products generated by the system that provide support for ecosystem sustenance and human needs (Thom et al. 2004) or the dynamic attributes which most directly affect metabolism, such as nutrient cycles and energy flux (SERI SPWP 2004)

**ecosystem processes:** the fundamental conditions and outputs of the ecosystem that can include biological, chemical and physical operations (Thom et al. 2004), which often refers to the mechanistic processes such as sedimentation or species colonization

**ecosystem structure:** the major habitat units in the system (e.g., emergent marsh, mud/sand flat; Thom et al. 2004)

**GIS:** geographic information system

**hypothesis:** a key prediction about what is expected to happen on the restoration site as a result of the restoration actions

**LiDAR:** light detection and ranging

**monitoring station:** a location where several biophysical samples occur within a small area

**NAVD88:** North American vertical Datum 1988

**objective:** what the project seeks to achieve

**opportunity:** the ability for site access following reconnection of tidal flow (e.g., the restoration provides an increase opportunity for fish to access the project)

**predictive model:** a model that incorporates current data to project future outcomes

**realized function:** the integration of opportunity, capacity, and the realized contribution of the site to biological resources (e.g., specific contribution of the restoration to juvenile Chinook: Evidence that juvenile Chinook is taking advantage of increased access to the restoration and the sites increased capacity to support prey resources. Evidence can be from comparing diet samples to prey availability, increased delta-rearing residence times, increased growth or rate of growth).

**RTK GPS:** real-time-kinematic geographic positioning system

## TABLE OF CONTENTS

1	INTRODUCTION	7
1.1	Salish Sea	7
1.2	Stillaguamish River Basin	7
1.3	Port Susan Bay and the Stillaguamish Estuary	8
1.4	Restoration Site and Reference Marsh	9
1.5	Restoration Scaling	9
2	PORT SUSAN BAY PROGRAM OBJECTIVES	10
3	PROJECT OBJECTIVES	12
3.1	Primary Objectives	12
1.	Restore self-sustaining native tidal wetlands that support estuarine-dependent animals (site scale)	12
2.	Improve juvenile salmon access to restored rearing habitats (site scale)	12
3.	Improve connectivity between the river and northern tidal habitats, increasing the distribution of freshwater, sediment, energy and other materials (estuary scale)	12
3.2	Secondary Objectives	12
4	MODELS AND HYPOTHESES FOR PORT SUSAN BAY	13
4.1	General Conceptual Model	13
4.2	Predictive Models	15
4.2.1	Hydrodynamic Model	16
4.2.2	Climate Change	16
4.2.3	Vegetation	17
4.2.4	Sediment	17
4.2.5	Channel Allometry	17
4.2.6	Biotic Response	18
4.3	Hypotheses and Rationale	18
5	KEY QUESTIONS AND UNCERTAINTIES	24
5.1	Climate Change	24
5.2	Hydrology and Sediment Dynamics	25
5.3	Faunal Response	26
5.4	Watershed Land Use Change	27
6	OPPORTUNITIES AND CONSTRAINTS	27
6.1	Ecosystem Services for Communities and Stakeholders	27

6.1.1	Flood Management and Infrastructure	27
6.1.2	Public Access and Recreation	28
6.2	Research Opportunities	28
6.3	Site Specific Constraints	29
7	MONITORING APPROACH	29
7.1	Why Monitor?	29
7.2	Adaptive Management	31
7.3	Before-After Control-Impact Design	32
7.4	Monitoring Stations	33
8	MONITORING GROUPS AND METHODS	33
8.1	Elevation	36
8.1.1	Topography	36
8.1.2	Bathymetry	37
8.2	Habitat	37
8.2.1	Photo-Points	38
8.2.2	Aerial Photography	38
8.2.3	Channels	40
8.2.4	Vegetation	40
8.3	Hydrology	41
8.3.1	Continuous Water Level, Temperature, Conductivity	41
8.3.2	Continuous Water Quality	42
8.3.3	Discrete Water Quality	42
8.3.4	Nutrients and Primary Productivity	43
8.3.5	Hydrodynamics	44
8.4	Sedimentation	44
8.4.1	Accumulation	44
8.4.2	Sediment Elevation	45
8.4.3	Soil Characteristics	46
8.5	Fauna	46
8.5.1	Invertebrates	46
8.5.2	Birds	48
8.5.3	Fish	49
8.6	Data	50
8.6.1	Data Analyses	50

8.6.2	Data Management	51
9	INFORMATION SHARING AND COMMUNITY OUTREACH	51
9.1	Learning and Sharing	51
9.2	Lessons Learned	52
9.3	Potential Monitoring Partners	53
9.4	Citizen Science	53
9.5	Web Portal	53
10	TIMELINE	53
11	ACKNOWLEDGMENTS	54
12	REFERENCES	56
13	APPENDICES	62
13.1	Photo-Point Standard Operating Procedures	63
13.2	RTK GPS Standard Operating Procedures	67
13.3	Channel Cross-section Standard Operating Procedures	69
13.4	Vegetation Transects and Survey Plot Standard Operating Procedures	71
13.5	Continuous Water Level, Temperature and Conductivity Standard Operating Procedures	80
13.6	Continuous Water Quality Standard Operating Procedures	87
13.7	Discrete Water Quality Standard Operating Procedures	94
13.8	Sediment Pin Standard Operating Procedures	96
13.9	Benthic Invertebrate Standard Operating Procedures	99
13.10	Terrestrial Invertebrates Standard Operating Procedures	101
13.11	Pelagic Invertebrates Standard Operating Procedures	103
13.12	Bird Area Survey Standard Operating Procedures	104
13.13	Variable Circular Plot Bird Survey Standard Operating Procedures	107
13.14	Habitat Mapping and Characterization	110
13.15	Salinity and Temperature Profiles Standard Operating Procedures	114
13.16	Potential Collaborators	115



## The Salish Sea

In 2009 the name 'Salish Sea' was officially approved in Canada and the United States. This name pays homage to the Coast Salish, one of the first inhabitants of the region.

The Salish Sea is the official name for the single estuarine ecosystem that extends from the north end of the Strait of Georgia west to the mouth of the Strait of Juan de Fuca and south to the southern end of Puget sound. The Salish Sea extends into British Columbia, Canada and Washington State, USA.

The Salish Sea is considered one of the most biologically rich inland seas in the world. In addition to the estimated 20 mammal species, 128 bird species, 219 fish species and over 3,000 invertebrates that use the waters of the Salish Sea (Brown and Gaydos 2007), approximately 7 million people live within its drainage basin.



The North Pacific Giant Octopus lives in the Salish Sea.

Photo Credit:  
<http://www.seadocsociety.org/Salish-Sea-Facts>

## 1 INTRODUCTION

### 1.1 Salish Sea

The Salish Sea, which includes the Puget Sound-Georgia Basin, consists of a network of interconnected coastal waterways and water bodies that reach as far north as Desolation Sound in the northern stretch of the Strait of Georgia in Canada to the Budd Inlet at the southern end of Puget Sound in Washington (Figure 1). The name Salish Sea is not a historical name, but was adopted out of the need for a single geographic term that encompassed the entire ecosystem. The name was officially recognized and approved by the United States in 2009 and by Canada in 2010 (WADNR 2009). As the second largest estuary in the United States, the Salish Sea supports an ecologically diverse ecosystem, with strong ties between a rich cultural heritage and diverse natural resources. The health and productivity of the region is key for the recovery of the natural resources, the maintenance of a vibrant economy, and a cornerstone of the quality of life for people (EPA 2011). Puget Sound is a 2,500 square kilometer area that is actively pursuing the recovery of Puget Sound ecosystems to ensure the protection of survival of key native wildlife populations, such as Chinook salmon (*Oncorhynchus tshawytscha*) and bull trout (*Salvelinus confluentus*).

### 1.2 Stillaguamish River Basin

From its headwaters in the Cascade Mountains, the Stillaguamish River drops from approximately 2,089 meters to sea level where it enters both Port Susan Bay and Skagit Bay. The Stillaguamish River Basin is approximately 800 square kilometers, is free of dams, and drains northern Snohomish and southern Skagit counties (SRBC 2003). The primary land use within the basin is forestry, almost three quarters of the Stillaguamish River Basin is considered commercially harvestable forestland agriculture. Other main land uses include: rural residences (17%), agriculture (5%), and a few areas of urban development (2%) such as the cities of Darrington, Granite Falls, Arlington, and Stanwood (Snohomish County 1995). The Stillaguamish River Basin falls within treaty-recognized "usual and accustomed" natural



resource area of the Stillaguamish Tribe.

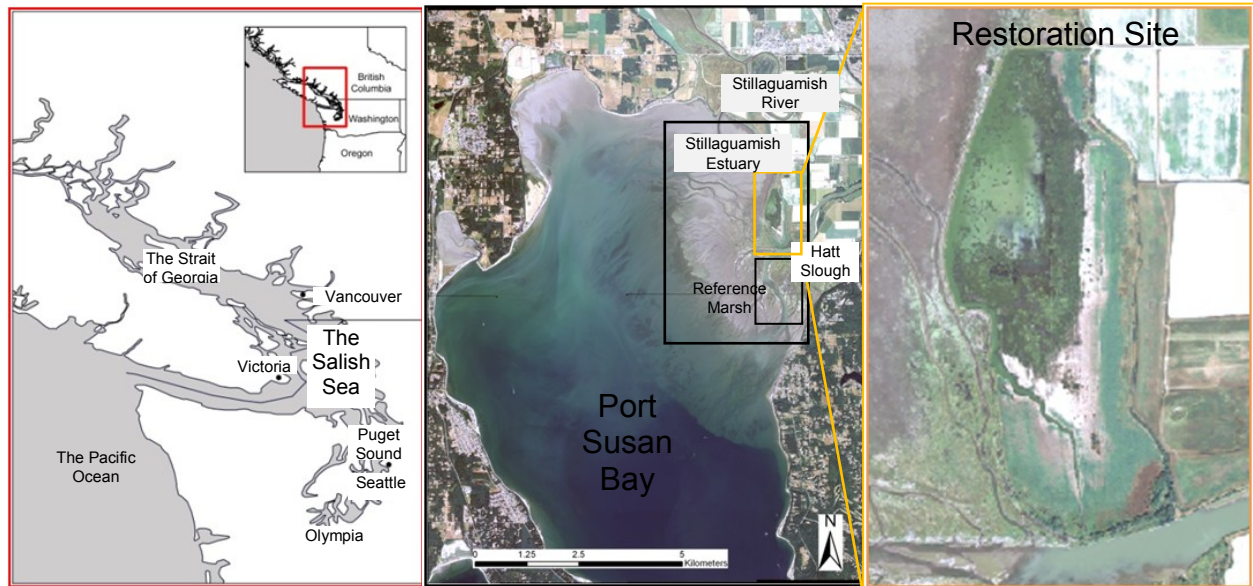

Figure 1. Restoration Site located in Port Susan Bay within Puget Sound of the Salish Sea, Washington, USA (North American Atlas 2006, National Agricultural Imagery Program 2009).

### 1.3 Port Susan Bay and the Stillaguamish Estuary

Within Puget Sound's Whidbey Basin lies Port Susan Bay (PSB), a protected embayment of 80 square kilometers that is located 26 kilometers north of Everett in northwestern Snohomish County (Figure 1). PSB is a site of ecological importance -- the region supports winter, spring, and fall habitats for shorebirds, geese, ducks, swans, and raptors. The estuarine, salt marsh, riparian, and agricultural habitats have been highlighted as part of the Western Lowlands Important Bird Area by Washington Audubon (Cullinan 2001). For example, PSB is considered one of four sites in Puget Sound that can support over 20,000 shorebirds within one season (Cullinan 2001). In addition to rich avian diversity, the Stillaguamish supports an array of important fish, including two populations of listed Chinook salmon (*Oncorhynchus tshawytscha*): North Fork summer Chinook and South Fork fall Chinook. The watershed is also home to Stillaguamish coho (*Oncorhynchus kisutch*) and Deer Creek coho (federally listed Species of Concern); North and South Fork pinks (*Oncorhynchus gorbuscha*) and fall chum (*Oncorhynchus keta*); South Fork, Deer Creek and Canyon Creek summer steelhead (*Oncorhynchus mykiss*; federally listed Threatened); Stillaguamish bull trout (*Salvelinus confluentus*; federally listed Threatened), and coastal cutthroat trout (*Oncorhynchus clarki*, federally listed Species of Concern).

Historically, the Stillaguamish River Estuary (hereafter, estuary) included 1,120 ha of estuarine emergent wetlands, 1,190 ha of shrub-scrub wetlands, and 2,010 ha of floodplain forests (Collins 2000). In the late 19<sup>th</sup> and 20<sup>th</sup> centuries most of the emergent wetlands, scrub-shrub and forested habitats were converted via diking to agricultural use (Collins 1997, 2000). What remains of the former estuary habitat is largely owned by TNC, making

restoration and monitoring decisions easier to make and to manage. Currently, in conjunction with partners, there are approximately 2,800 ha of intertidal and nearshore habitat currently under conservation protection in northern PSB (R. Fuller pers. com.). The Stillaguamish River is the primary river entering PSB and the fifth largest tributary to Puget Sound, discharging on average 3,700 cfs. The river is a major source of fine sediment within PSB, while coarse material is primarily derived locally from coastal erosive processes (Griffith 2005). Historically, PSB was part of the greater Stillaguamish-Skagit-Samish river delta system, where all three rivers met in a large, uninterrupted estuary. Currently, PSB still maintains a hydrologic connection with the Skagit estuary to the north, but the flow is much reduced from historic levels. The Stillaguamish estuary is approximately 2160 ha, and includes the Port Susan Bay Preserve which spans both of the major river distributaries, Hatt Slough and South Pass, at the northern end of PSB. The Nature Conservancy acquired the 1,600 ha Port Susan Bay Preserve and has been managing the property since 2001. The nearshore habitats in PSB are important habitat for juvenile Chinook as they move from the estuary system out into PSB. The Stillaguamish estuary and PSB fall within the “usual and accustomed” natural resource areas of the Tulalip and Swinomish Tribes.

### 1.4 Restoration Site and Reference Marsh

The PSB estuary restoration project will remove an existing sea dike at the 60 ha restoration site at the mouth of the Stillaguamish River, thereby restoring natural riverine and tidal processes in the estuary (Figure 1). The restoration site was diked in the 1950s and was agricultural until the 1990s (Yang et al. 2010). Currently, the elevation within the restoration site has subsided approximately one meter below the adjacent marsh (Yang et al. 2010). The restoration site is currently composed of two habitat types: diked upland and diked wetland. The lowest elevation area within the restoration site is in the northwestern region where water collects to form a large pond. Tidal habitat will be restored in the area currently protected by the dike, and ecological connectivity will be improved between the river and existing tidal marshes west and north of the project. The reference marsh is approximately 57 ha, located south of the restoration site on the southern side of Hatt Slough (Figure 1), and comprised of high marsh, low marsh, and vegetated mud flat.

### 1.5 Restoration Scaling

The Stillaguamish River Basin is a medium-sized watershed, making it easier and less resource intensive to monitor and to see system-scale responses than a large river, but also insuring that observations are relevant to river systems of any size. While restorations are typically designed, implemented and managed individually, at the local project or site level, TNC is explicitly interested in both the site level and estuary-wide responses to the restoration action. As such, project objectives have been designed to examine two scales of interest.

**Site-scale:** This scale includes the restoration site and the adjacent reference marsh, and is intended to examine the development of habitat and functions on the footprint of the project. The similar-sized reference marsh will allow the

development of the restored marsh to be compared with a marsh that has never been diked. Monitoring objectives and methods that are designed to examine this scale will be described as “site-scale.”

**Estuary-scale:** This scale describes is the overall influence of the restoration action on the entire estuary ecosystem. The project site is at the mouth of the main river distributary and we therefore expect to see project effects on estuary-scale processes such as the distribution of freshwater and sediment. Monitoring objectives and methods that are designed to examine this scale will be described as “estuary-scale.”



Example of a photo-point at the Northwest corner of the restoration site facing Port Susan

## 2 PORT SUSAN BAY PROGRAM OBJECTIVES

TNC is involved in tidal marsh conservation, coastal ecosystem services, climate change adaptation and related policy issues around the globe. It is widely recognized that estuarine ecosystems support diverse wildlife populations. Thus, this restoration, in concert with other restorations and conservation activities, is expected to result in increased regional ecological functions and services ranging from flood attenuation, increased estuarine connectivity for estuarine dependent wildlife, increased food resources for fish and bird communities, enhanced ecosystem services for local cultural and economic community values, greater stewardship of restoration lands, the advancement of restoration science, and knowledge transfer to the restoration community in the greater Puget Sound. Actions taken in Port Susan Bay will also contribute to the impact of conservation and restoration efforts in nearby Skagit Bay, as well as broader efforts throughout Puget Sound.

The scale of TNC ownership and the character of natural and human community dynamics at Port Susan Bay make it an ideal place to learn better methods of conservation in the context of community, and to share those lessons broadly. As a result of regional and organizational needs, the PSB program has established a key objective of advancing the science and practice of estuarine restoration and stewardship through innovative and experimental actions and research, documented and shared globally and regionally.

The restoration project is one of several strategies being implemented by The Nature Conservancy (TNC) as part of its Port Susan Bay Program. To provide context for the restoration project's objectives which are described later, this section describes the broader objectives of TNC's Port Susan Bay Program.

The Port Susan Bay Program is a large-scale, long-term effort to restore a functional estuary within the context of a vibrant agricultural working landscape. This work is guided by the conservation targets outlined in the Conservation Area Plan developed for the greater Skagit Delta (Fuller 2004). **The long-term vision of the Port Susan Bay Program is to restore a functional estuarine ecosystem that is resilient to ongoing threats and adaptable to climate change.** To accomplish this vision, objectives have been developed in three focal areas described below: (1) Ecological, (2) Community and Working Lands, and (3) Learning, Sharing and Influencing (paraphrased from Warren unpubl. comm., Fuller, unpubl. comm.). The program's vision and objectives will be revisited in 2011, pending completion of TNC's Puget Sound Business Plan.

### Ecological

- Protect and restore a biophysical template throughout the estuarine gradient, from river delta to marine, that supports a diversity of ecosystem processes, functions, habitats, species and life histories;
- Restore connectivity among marine, estuarine, and terrestrial habitats to support ecosystem processes and species movements;
- Sufficient space and corridors for habitat migration in response to climate change;
- Reduce threats to estuarine health including invasive species, water quality, resource harvest, and altered hydrogeomorphology to a level that requires minimal management input;

### Community and Working Lands

- Protect and enhance ecosystem services that support local community cultural and economic values;
- Build strong local support for ecosystem protection and restoration;
- Protect and enhance habitat functions in the surrounding agricultural landscape to support estuarine biodiversity;

### Learning, Sharing and Influencing

- Advance the science and practice of estuarine restoration and stewardship through innovative and experimental actions and research, documented and shared regionally and globally;
- Collaborate with other Puget Sound river delta restoration programs to maximize learning, information exchange and tool development

### 3 PROJECT OBJECTIVES

The Port Susan Bay estuary restoration project will remove an existing sea dike at the mouth of the Stillaguamish River, thereby restoring natural riverine and tidal processes. Tidal habitat will be restored on the 60 ha protected by the dike, and ecological connectivity will be improved between the river and existing tidal marshes west and north of the project. The goal of removing the dike at the mouth of the river is to enhance ecological functions in the estuary and to improve flood attenuation in the delta (K. Morgan, TNC; unpubl. comm.). The project will promote a healthy estuary over time, benefiting people as well as juvenile salmon, shorebirds, and other estuarine-dependent animals.

#### 3.1 Primary Objectives

##### *Ecological*

1. Restore self-sustaining native tidal wetlands that support estuarine-dependent animals (site scale)
2. Improve juvenile salmon access to restored rearing habitats (site scale)
3. Improve connectivity between the river and northern tidal habitats, increasing the distribution of freshwater, sediment, energy and other materials (estuary scale)

##### *Community and Working Lands*

4. Improve flood attenuation for neighbors in lower river valley

#### 3.2 Secondary Objectives

##### *Learning, Sharing and Influencing*

1. Develop and test results of restoration predictive models, including hydrodynamic, climate change adaptation, vegetation, sediment, channel allometry, and biotic response
2. Provide opportunities for knowledge creation and transfer

##### *Community and Working Lands*

3. Create opportunities for the public to experience and learn about estuary restoration

For this project, monitoring will address the primary objectives in detail (Table 1), while the secondary objectives will be realized through sharing of knowledge and experience gained from the monitoring as well as by engaging the community in the process of discovery. Objectives 1 and 2 address processes occurring within the restoration project at the site scale. Objective 3 is focused on the influence of the restoration at the estuary scale.



## 4 MODELS AND HYPOTHESES FOR PORT SUSAN BAY

This section describes the general ecosystem conceptual model for the Stillaguamish estuary, as well as the predictive models and resulting hypotheses on which the restoration project is based.

### 4.1 General Conceptual Model

Restoring natural estuarine processes are ever-changing, which results in a shifting mosaic of habitat types. Models are useful tools to predict potential end points of restoration actions and incorporate uncertainties. Adaptive modeling approaches can assist landscape scale restorations achieve their goals and understand system-scale processes (Zedler 2005). Given the dynamic processes at play within ecosystems including external regulatory processes, the influence of natural and human disturbances, and random effects (e.g. storm events), conceptual and simulation models are vital to understanding the uncertainties and potential trajectories of these open systems (Pickett and Parker 1994; Parker and Pickett 1997; Wissmar and Bisson 2003, Zedler 2005). Models can be used to represent restoration and resilience potential (Bennett et al. 2005), attempt to incorporate uncertainties, and take into account multiple system processes. A conceptual model of estuarine processes, controlling factors, and structures was developed for the Stillaguamish estuary (Figure 2).

Figure 2. Conceptual model of the Port Susan Bay ecosystem. Box shading corresponds to the number of other attributes affected by each component (darker= more attributes affected). Model structure is based on Thom et al. (2004).

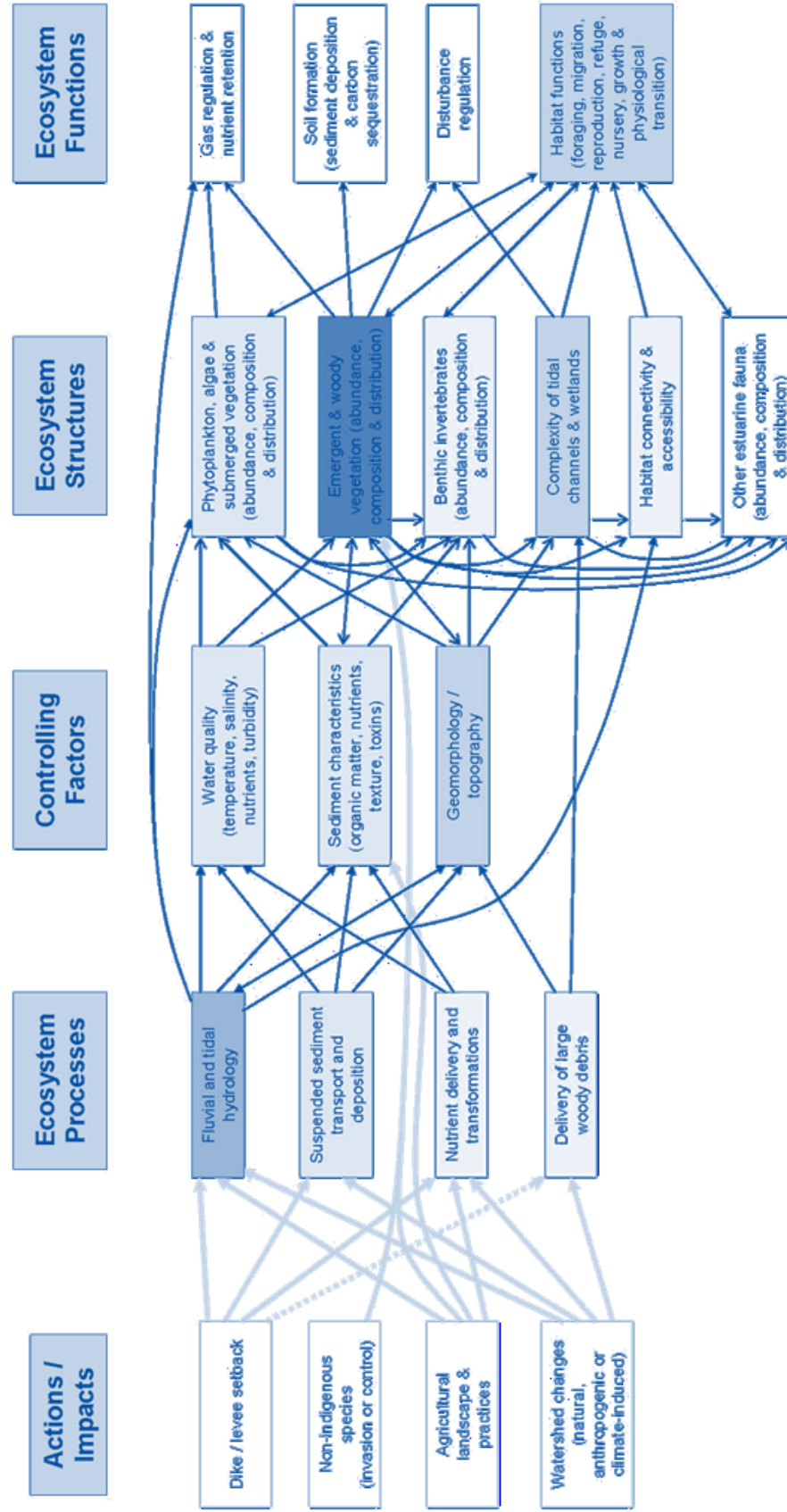



## 4.2 Predictive Models

The National Oceanic and Atmospheric Administration (P. Cereghino), TNC (R. Fuller), and the Washington Department of Fish and Wildlife Estuary and Salmon Restoration Program (B. Lyons) sponsored a river delta restoration and monitoring workshop on 3 December 2010. It was attended by 50 estuary restoration experts from throughout Puget Sound and the Strait of Juan de Fuca. The experts were asked to list important restoration questions that need to be answered and to identify the most important questions in several categories. Though the questions spanned a wide array of biological, ecological, physical, chemical, social and economic questions as well as different spatial and temporal scales, the great majority revolved around the issue of having adequate models to guide the selection, design and implementation of restoration projects.

The most pressing needs for predictive models, as confirmed by workshop participants, include hydrodynamics, climate change, marsh vegetation, sediment, channel allometry, and fish and bird response. Predictive models allow you to establish reasonable expectations for physical and biological outcomes from restoration, as well as understand the cumulative effects of multiple projects on long term estuary function and resilience. Furthermore, predictive models can directly inform project design by projecting the relative merits of alternative choices such as dike breaching vs. dike removal, channel excavation vs. allowing natural hydraulics to carve channels, or planting vs. natural recruitment. In every restoration project, there are many design choices that both practitioners and their funders must evaluate. Without regionally relevant predictive models to clarify ecological outcomes, choices are often made based on non-ecological criteria, directly affecting our ability to learn and improve our restoration methods. In Puget Sound, some of these models have begun to be built, but have mostly been developed at specific sites such as the Skagit River Delta, and haven't yet been developed into regional tools. Port Susan Bay provides an ideal opportunity to develop and test these models and to begin to coordinate with other sites in the expansion of the models into regionally relevant restoration tools.

Currently, some of the predictive models for this project are quantitative and are associated with algorithms that apply local data to make predictions of restoration effects. Other models are still only conceptual and describe in text or image the predicted effects of restoration, based on expert knowledge and application of the literature to known site conditions. Before project construction, we hope to make each of the predictive models quantitative, though some will necessarily be quite simple. Through post-project monitoring, these models will be tested, improved and developed into more quantitative predictive models to inform adaptive management and to build better regional restoration design tools.

Predictive models are described briefly below.

### 4.2.1 Hydrodynamic Model

A quantitative, 3-D hydrodynamic model was developed to assess the potential changes of physical processes that will result from the removal of the dike at the restoration site (Dunwiddie et al. 2009, Yang et al. 2010). As such, the model included observed river flows, water levels, tides, salinities, and currents to simulate hydrological responses to dike removal. Model output suggests that dike removal will increase freshwater distribution and residence time, reducing salinity in the northern estuary, which can facilitate the colonization of tidal marsh vegetation (Figure 3).

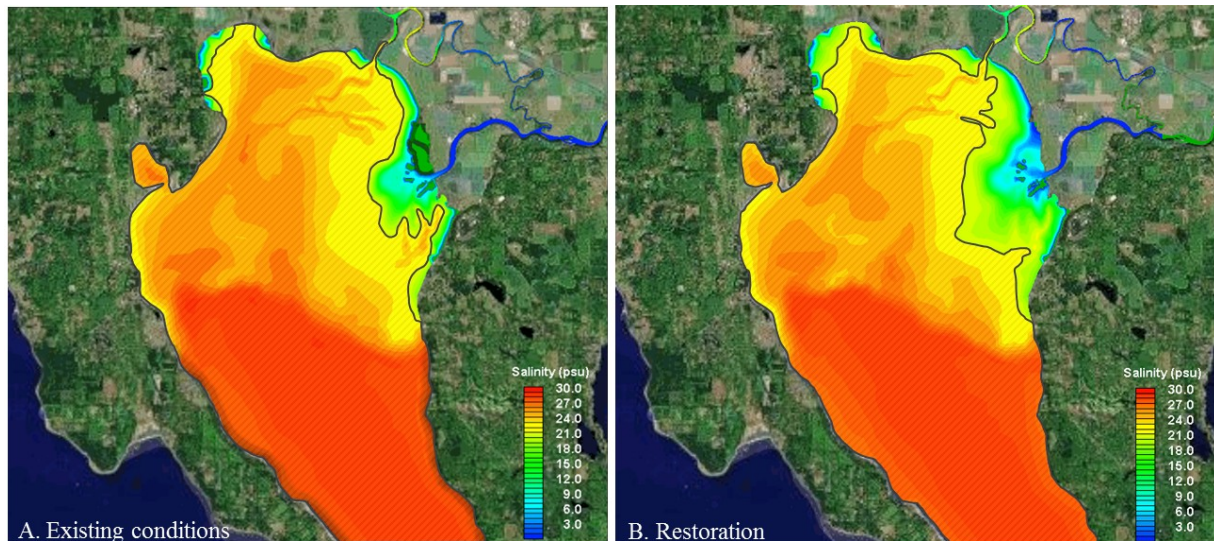

Figure 3. Modeled salinity distribution at flood tide in Port Susan Bay A) under existing conditions and B) with proposed dike removal at the restoration site. The hatched area (lighter, yellow and orange areas) indicates where salinity exceeds 21psu, which is near the upper tolerance limit for most estuarine vegetation (Figure from Dunwiddie et al. 2009).

### 4.2.2 Climate Change

In 2009, a Sea Level Affecting Marshes Model (SLAMM) model (Park et al. 1989; [www.warrenpinnacle.com/prof/SLAMM](http://www.warrenpinnacle.com/prof/SLAMM)) was developed for Port Susan Bay at a 5 m scale that included accretion feedbacks and calibrated salinity (Clough and Larson 2010). The models were run with five remediation scenarios to examine the effects of dike placement, altered flow regimes, and marsh predation by snow geese. Local scenarios of Sea Level Rise estimates were used in model development (intermediate = 59 cm rise by 2100, very high = 100 cm by 2100). The methods in this monitoring framework directly acquire the physical data necessary to update the SLAMM model for PSB including: inundation, erosion-accretion, high-resolution elevation, channel morphology, and salinity. Furthermore, inundation data for the model analyses were collected from a NOAA gage south of Port Susan Bay. Inundation data gleaned from water level loggers will provide site-specific high-resolution inundation rates. Site-specific hydrodynamic data will include monitoring of flood tides at PSB monitoring stations in addition to recording time, date, water temperature and salinity. These data will assist the downscaling of tide heights within the marsh plain and channels.

### 4.2.3 Vegetation

The composition and condition of the vegetative community influences the spatial distribution and use by wildlife. Colonization and establishment of marsh vegetation are reliant on the underlying sediment characteristics, elevation, and water quality (e.g. salinity) of the site. Removal of the dike will reintroduce tidal flow to the restoration site which will increase sediment and organic inputs to the site, thereby increasing site elevation over time. The reduced salinity expected upon dike removal coupled with eventual increased elevation will promote conditions for marsh plant establishment. Likewise, removal of the dike is expected to change the system-scale distribution of freshwater and sediment to the marsh areas west and north of the restoration site, likely resulting in vegetation changes. Quantitative predictions of vegetation change on the site have been developed (Yang et al. 2010) and data collection will assist the further development of these models.

### 4.2.4 Sediment

The rate of sediment accretion or erosion is a primary determinant of tidal wetland sustainability with sea level rise and a primary driver of habitat evolution over time. Accretion rates vary spatially due to many factors including elevation, vegetation type and productivity, distance to channels, wave climate, and salinity dynamics. Dike removal will increase site inundation which will increase sediment deposition within the restoration footprint, and facilitate channel development. Likewise, dike removal will alter sediment delivery patterns to tidal areas west and north of the project, which is expected to affect accretion rates at a broad scale. Elevation of the mud flat and the associated inundation frequency and duration are critical to understanding the potential vegetation community that will colonize post restoration actions. Water quality and level data collected will serve as essential baseline data to support sediment transport processes and circulation model simulations, and to support the development of hydrodynamic and sediment transport (HST) models to examine the effects of restoration on the estuary. We expect to develop quantitative predictions of sediment accretion prior to project construction.

### 4.2.5 Channel Allometry

Tidal creeks and channels are an important drainage and habitat feature of tidal salt marshes. They influence biological and physical characteristics such as plant and avian distributions, fish and invertebrate establishment, and soil biogeochemistry (Callaway et al. 2001, Zedler 2000, Hood 2006, Hood 2007). Altered hydrologic processes will allow new channels to develop within the restoration footprint, which will increase the site's capacity to support marsh development and use by fish and birds. In addition, the increased tidal prism of the restored area will lead to dimensional changes in nearby distributary and blind tidal channels which will affect tidal processes and biotic connectivity across a broader area. We expect to develop quantitative predictions of channel evolution prior to project construction.

#### 4.2.6 Biotic Response

Dike removal at the restoration site will alter physical properties of the area that will result in the response of invertebrates, fish, and birds. Species responses may include number, duration of stay, species composition, seasonal dynamics, productivity, in addition to other responses. For example, re-introducing tidal influence and eliminating the non-tidal pond within the restoration footprint may result in a decrease in certain shorebird species and an increase in others.

### 4.3 Hypotheses and Rationale

Restoration sites can be designed to incorporate a scientific approach that will provide valuable information for future restorations and contribute to the growing body of restoration ecological knowledge. Hypotheses provide a scientific framework for restoration projects. They are critical to an approach focused on learning and improving the practice of restoration. Hypotheses document our assumptions about how our actions will achieve our project objectives. They are based on our understanding of how our conservation targets will respond to restoration. In other words, our hypotheses are based on our predictive models. By clearly documenting our expectations and then measuring the actual outcomes, we can improve the effectiveness of future restoration projects. Monitoring provides the ability to compare project outcomes with expectations, and it is the tool that allows us to learn how to be more effective.

Each of our project objectives is based on a series of hypotheses that we think will cumulatively result in a successful objective. Our objectives are described below, followed by their underlying hypotheses. The monitoring program for this project is based on measuring project outcomes relative to these hypotheses. Table 1 summarizes the hypotheses, their associated predictive models, and the metrics that will assess how well project outcomes match the hypotheses.

#### ***Objective 1. Restore self-sustaining native tidal wetlands that support estuarine-dependent animals (Site Scale)***

H1.1. Site elevations, inundation levels and salinities will support the establishment of high marsh, low marsh and tide flat

*Rationale:* Site specific hydrodynamic models (Yang et al. 2010) suggest that restoration actions will result in the development of high and low marsh covering half of the restored site. Models predict minimal changes in salinity and increased inundation levels which should not limit marsh plant colonization (Ewing 1986).

H1.2. Restored tidal exchange and inundation will result in sediment accretion on the marsh plain, initially rapid until site elevations approach elevations in adjacent marsh

*Rationale:* Based on results of hydrodynamic modeling, the removal of the dike will restore tidal flow to the restoration area, becoming fully inundated during high tides and mostly evacuated during low tides (Yang et al. 2010).

The increased amount of time that the marsh plain is flooded will increase the amount of suspended sediments that can settle onto the marsh plain and facilitate marsh accretion (Hood 2009, Friedrichs and Perry 2001).

H1.3. Restored inorganic and organic accretion will result in accretion rates that will keep up with moderate projections for local sea level rise

Rationale: Based on the simulations of SLAMM models developed for Port Susan Bay, a low projection (0.34 m by 2100) of sea level rise should not dramatically alter the conditions of the marshes and tidal flats. Intermediate levels (0.59m by 2100) of sea level rise will reduce vegetated tidal flats, but “regularly flooded salt marshes and irregularly flooded marshes” should “remain resilient” (Clough and Larson 2010). However, recent estimates of SLR including melting ice are much higher (Vermeer and Rahmstorf 2009).

H1.4. Restored tidal exchange will re-introduce sediment transport and scouring of tidal channels on the project site, resulting in the development of a complex blind tidal channel network

Rationale: Tidal channels are sculpted by the hydraulic energy of the tidal prism. Restored tidal prism will increase the energy available to carve channels and transport sediment, resulting in a larger and more complex blind tidal channel system on the site.

H1.5. Restored tidal inundation patterns will facilitate site use by a diversity of birds

Rationale: As seen in other salt marsh restoration sites, once full inundation patterns are restored, dabbling ducks and shorebirds will readily use the sites at high and low tide, respectively (Woo et al. 2007). Native vegetation, full tidal inundation and evacuation, water depth, and food resources are critical components driving waterbird habitat use (Neckles et al. 2002).

H1.6. Restored tidal exchange will result in fine and organic sediment qualities that support primary productivity and benthic invertebrate prey of shorebirds

Rationale: Invertebrates are important indicators of water quality and ecological integrity of marsh habitats (USEPA 2002). Increased sediment accretion due to organic and inorganic inputs in the restored area will provide the components necessary for the colonization and increase of benthic invertebrate populations (Craft 2000).

### ***Objective 2. Improve juvenile salmon access to restored rearing habitats (Site Scale)***

H2.1. Juvenile Chinook salmon will utilize new channels and marsh at densities similar to the reference marsh, adjusted for channel allometry differences

Rationale: Removal of the dike will allow salmonid access to newly restored habitats.



H2.2. As a new tidal channel system develops and expands, juvenile Chinook use will similarly expand

*Rationale:* The restoration of tidal action will increase both sediment transport and channel scouring that will develop a new tidal channel system within the site. Increased access and channel complexity will increase the amount and availability of habitat for salmonids.

***Objective 3: Improve connectivity between the river and northern tidal habitats, increasing the distribution of freshwater, sediment, energy and other materials (Estuary Scale)***

H3.1. Accretion rates in existing marsh and tide flat north of Hatt Slough will increase and accretion rates south of Hatt Slough will not change

*Rationale:* The Stillaguamish River is a major source of fine sediment to Port Susan Bay (Griffith 2005). Currently, the 60 ha diked area at the mouth of the Hatt Slough constrains the distribution of this sediment to much of the estuarine system, specifically to areas north of Hatt Slough (Yang et al. 2010). Dike removal will allow unimpeded movement of sediment from the river into these areas resulting in increase accretion rates.

H3.2. Water column and pore-water salinity will decrease north of Hatt Slough and will not change south of Hatt Slough

*Rationale:* Hatt Slough is the primary river channel carrying freshwater to Port Susan Bay. Currently, the 60 ha diked area at the mouth of the Hatt Slough constrains the distribution of this freshwater to much of the estuarine system, specifically to areas north of Hatt Slough. Dike removal will allow unimpeded movement of freshwater from the river into these areas resulting in reduced water column and pore-water salinity, while not changing salinities south of Hatt Slough (Yang et al. 2010).

H3.3. Distributary and blind tidal channel systems north of Hatt Slough will expand in size and complexity

*Rationale:* The dike and levee system have altered the hydrodynamics of Hatt Slough as it enters Port Susan Bay, carrying greater energy past the historical estuary into the deeper waters of the bay, thereby reducing the potential for channel development north of the restoration area. Increasing the tidal prism north of Hatt Slough will increase the hydraulic energy available to scour channels. Dike removal may lead to changes in hydrogeomorphic dynamics and evolution of tidal channels (Hood 2004a,b; Yang et al. 2010).

H3.4. The amount of large woody debris will increase in the tidal marsh north of Hatt Slough

*Rationale:* The dike and levee system has altered the hydrodynamics of Hatt Slough as it enters Port Susan Bay, carrying greater energy past the historical

estuary into the deeper waters of the bay. Dike removal will allow for unimpeded movement of large woody debris from the Stillaguamish River into the tidal marsh north of Hatt Slough.

H3.5. Tidal marsh area west and north of the restoration footprint will expand

*Rationale:* Currently, flood tide salinities west and north of the restoration footprint are near the upper tolerance limit of most brackish tidal marsh plant species. Site specific hydrodynamic models (Yang et al. 2010) suggest that restoration will result in reduced salinities in these areas. In addition, increased accretion rates (H3.1) will increase the area at elevations that support tidal marsh.

### ***Objective 4: Improve flood attenuation for neighbors in lower river valley***

H4.1. After major events that flood Florence Island, the number of hours before water levels recede to the invert elevation of the new floodgate will be reduced

*Rationale:* Hypothesis is based on regional observations of pinch points and flooding processes in the Stillaguamish region.

H4.2. During minor flood events, removal of the dike will improve flood water evacuation on the lower tidal reach of the river corridor, raising the flood volume at which minor flooding occurs

*Rationale:* The restoration will increase the area over which floods will spread and increase the capacity for water evacuation and storage.



Table 1. The restoration monitoring objectives and underlying hypotheses are listed in conjunction with available knowledge regarding pre-project site and estuary conditions. Predictive models are associated with each hypothesis and will be updated as data become available. Restoration targets are the anticipated outcomes of the restoration action as they pertain to specific hypotheses. Performance metrics describe the expected biological and physical responses to the restoration that would indicate the support of biological access (opportunity), potential use (capacity), and actual use (realized function) at the restoration site. Monitoring groups refer to the collection of methodologies that will be used to assess the objectives and associated hypotheses, and are further discussed in the Section 8.

Restoration Objectives (Sec. 3.1)	Hypotheses (Sec. 4.3)	Pre-Project Condition (Sec 7.3)	Predictive Model (Sec. 4.2)	Restoration Target	Performance Metrics			Monitoring Group (Sec. 8.1-8.5)
					Opportunity	Capacity	Realized Function	
Site Scale								
<b>Objective 1:</b> <i>Restore self-sustaining native tidal wetlands that support estuarine-dependent animals</i>	H1.1. Site elevations, inundation levels and salinities will support the establishment of high marsh, low marsh and tide flat	Current acreage of high marsh, low marsh and tide flat TBD	hydrodynamic, vegetation	Acreage of high marsh, low marsh and tide flat restored will be determined	Tidal exchange (tidal inundation and drainage) will be reintroduced to the restoration site. Structural components (i.e., elevations and channels) that support the development of high marsh, low marsh, and tide flat will be restored; tide waters will evacuate site completely. Processes of full tidal inundation and evacuation, salinity incursion, development of high and low marsh and tide flat will be self- sustaining			elevation, hydrology, habitat, sedimentation
	H1.2. Restored tidal exchange and inundation will result in sediment accretion on the marsh plain, initially rapid until site elevations approach elevations in adjacent marsh	Sedimentation or subsidence rates will be determined from 2011 and 2005 LiDAR	sediment	Tidal exchange and sediment elevation will approach that of the reference marsh	The restoration of tidal flow will provide a medium for sediment transport. Sediment sources from the bay or river will transport and deposit sediment into the project. Processes of sediment accretion will be sufficient to sustain the viability of vegetated marsh though time			elevation, sedimentation, hydrology, habitat
	H1.3. Restored inorganic and organic accretion will result in accretion rates that will keep up with moderate projections for local sea level rise	Sedimentation or subsidence rates will be determined from 2011 and 2005 LiDAR	climate change	Inorganic and organic accretion will be similar to that of the reference marsh	Contributions to surface elevations within the project consist of inorganic sediment and organic matter from vegetation. Inorganic and organic contributions to elevation will be sufficient for marsh colonization and establishment. Processes for inorganic and organic inputs to elevation will be sufficient for marsh resiliency with projected sea level rise			elevation, sedimentation, habitat, hydrology
	H1.4. Restored tidal exchange will re-introduce sediment transport and scouring of tidal channels on the project site, resulting in the development of a complex blind tidal channel network	Currently, site does not receive tidal exchange. Post construction as-built survey is recommended	hydrodynamic, channel allometry	Increased channel network and blind channel habitat types	Restoration of tidal exchange within the project will promote natural channel development within the project. Restoration of tidal flow within the project will influence hydrodynamics, sediment accretion, and sediment scour for natural channel development within the estuary. Natural processes that lead to the development of channels (i.e., blind channels) within the estuary will be self-sustaining			habitat, elevation, hydrology, sedimentation, fauna
	H1.5. Restored tidal inundation patterns will facilitate site use by a diversity of birds	Surveys show site use by a diversity of species that vary seasonally.	hydrodynamic, fauna	Restoration will benefit a diversity of estuarine bird species	Habitat for estuarine birds will increase and provide foraging access for different estuarine bird guilds	The restoration will provide food resources and increased prey production	Estuarine birds will use the site for foraging. Processes that influence avian habitat use will be self-sustaining	hydrology, elevation, habitat, fauna
	H1.6. Restored tidal exchange will result in fine and organic sediment qualities that support primary productivity and benthic invertebrate prey of shorebirds	42 taxa represented by 14 classes were collected in 2005. Higher elevations had finer substrates (Heatwole 2006).	hydrodynamic, sediment, fauna	Benthic invertebrates prey will not be limiting for estuarine birds in the estuary	The restoration and surrounding estuary will provide increased habitat for foraging shorebird guilds	The restoration and estuary produces benthic invertebrate prey resources for shorebirds	Shorebird use the site and estuary for foraging as confirmed by diet similarities to available prey resources at site	hydrology, elevation, habitat, fauna, sedimentation

Table 1. continued

Restoration Objectives (Sec. 3.1)	Hypotheses (Sec. 4.3)	Pre-Project Condition (Sec. 7.3)	Predictive Model (Sec. 4.2)	Restoration Target	Performance Metrics			Monitoring Group (Sec. 8.1-8.5)
					Opportunity	Capacity	Realized Function	
<b>Objective 2:</b> <i>Improve juvenile salmon access to restored rearing habitats</i>	H2.1. Juvenile Chinook salmon will utilize new channels and marsh at densities similar to the reference marsh, adjusted for channel allometry differences	Site is currently not accessible for fish	fauna, channel allometry	Restoration benefits for salmonids will approach that of the reference marsh	Restored marsh and new channels will increase habitat connectivity and access for salmonids	The restoration and new channels will provide the structures, water flow, and food resources for salmonids	Salmonids will use the restoration for foraging. Processes that maintain channel and habitat connectivity will be self-sustaining	habitat, fauna, elevation, hydrology
	H2.2. As a new tidal channel system develops and expands, juvenile Chinook use will similarly expand	Site is currently not accessible for fish	fauna, channel allometry	Increased channel network and blind channel habitat types will increase salmonid use	New and developing channels and sloughs will increase habitat connectivity and access for salmonids	Tidal channel networks will develop and expand, providing increased structures, water flow, and food resources for salmonids	Salmonids use of new and developing channels will increase as habitat and food resources increase	habitat, fauna, elevation, hydrology
Estuary Scale								
<b>Objective 3:</b> <i>Improve connectivity between the river and northern tidal habitats, increasing the distribution of freshwater, sediment, energy and other materials</i>	H3.1. Accretion rates in existing marsh and tide flat north of Hatt Slough will increase and accretion rates south of Hatt Slough will not change	Accretion rates will be determined by difference between 2011 and 2005 LiDAR	sediment	Dike removal will result in sediment accretion in the tide flat north of Hatt Slough	Dike removal will restore natural sedimentation processes within the estuary and sediment accretion will occur within subsided areas of the restoration			sedimentation, elevation, habitat, hydrology
	H3.2. Water column and pore water salinity will decrease north of Hatt Slough and will not change south of Hatt Slough	Pore water salinity north of Hatt Slough and south of Hatt Slough TBD (Heatwole 2006)	hydrodynamic	Dike removal will result in decreased salinity north of Hatt Slough	Dike removal will increase freshwater circulation and influence salinities within the estuary. Vegetation communities will respond to changes in salinity			hydrology, elevation, habitat
	H3.3. Distributary and blind tidal channel systems north of Hatt Slough will expand in size and complexity	Channel allometry will be determined from pre-restoration aerial photos and bathymetry	hydrodynamic, channel allometry	Increased channel complexity and development in estuary	Dike removal will have estuary-wide impacts for hydrology and sedimentation dynamics. The restoration will facilitate increased channel development and channel complexity in surrounding sloughs			habitat, elevation, hydrology, sedimentation, fauna
	H3.4. The amount of large woody debris will increase in the tidal marsh north of Hatt Slough	Number of LWD in tidal marsh north of Hatt Slough TBD by aerial photographs	hydrodynamic	Processes that allow for natural transport and habitat functions of large woody debris	Dike removal will allow free movement and deposition of the large woody debris down Hatt Slough and into the tidal marsh. Large woody debris movement will not be restricted by dikes and will create habitat for salmonids throughout the estuary			habitat, elevation, hydrology, fauna
	H3.5. Tidal marsh area west and north of the restoration footprint will expand	Current tidal marsh extent TBD	vegetation	Increased acreage of tidal marsh	Sediment processes will be restored to allow for the expansion of tidal marsh west and north of the restoration footprint			habitat, elevation, hydrology, sedimentation
<b>Objective 4:</b> <i>Improve flood attenuation for neighbors in lower river valley</i>	H4.1. After major events that flood Florence Island, the number of hours before water levels recede to the invert elevation of the new floodgate will be reduced	Number of hours passes before water levels recede to the invert elevation of the new floodgate TBD	hydrodynamic	New floodgate will improve drainage following flood	New floodgate will promote water evacuation. Tide gate will improved drainage following flood events. Restoration will increase channel scour and drainage. Tide gate in combination with channel development and natural estuarine flood attenuation will convey water off lands			hydrology, habitat, elevation
	H4.2. During minor flood events, removal of the dike will improve flood water evacuation on the lower tidal reach of the river corridor, raising the flood volume at which minor flooding occurs	Flood volume at which minor flooding occurs will be determined in cubic feet per minute	hydrodynamic	Restoration reduces frequency and or duration of flooding events to upstream parcels	Restoration will provide temporary storage of flood waters. Restoration will increase channel scour and channel complexity to provide temporary storage of flood waters and increased drainage. Natural processes will maintain estuarine flood attenuation, channel drainage, and floodgate operations; raising flood stage for minor flooding			hydrology, elevation

## 5 KEY QUESTIONS AND UNCERTAINTIES

Estuarine restorations involve complex ecological and social processes and multiple scales of influence. A few key guiding “big picture” questions will require collective learning and inputs from the entire restoration community. Yet every restoration plays a vital role at the local level and has the opportunity to increase wildlife habitat value and people’s awareness and connection to the land.

- How vulnerable are systems and communities to Climate Change?
  - o How do climate and anthropogenic changes in the Stillaguamish watershed and Port Susan Bay affect processes key to estuary resilience and adaptability?
  - o Can restoration of estuarine habitats lead to improved processes and functions at scales that are the key to long-term estuary resilience and adaptability?
- What influences hydrology and sediment dynamics?
  - o What is the condition of the soil within the restoration site?
- How will the biota respond?
  - o How will birds respond at the flyway scale?
  - o How will fish respond at the watershed scale?
  - o How do the cumulative effects of management actions (at all scales) lead to greater estuary resilience and adaptability over time?
- What are the expected basin-wide changes in population and land use?
  - o What management actions or project designs are likely to have the greatest long-term impact on processes and functions?

### 5.1 Climate Change

Understanding the potential effects of climate change at PSB and facilitating the development of an estuary that is resilient and adaptable to climatic change will require the integration of the majority of monitoring protocol employed in this plan. Under a global average sea level increase of 0.69 meters, Glick et al. (2007) predict a cumulative 77% loss of brackish marshes and 91% loss of estuarine beaches by 2100 within Padilla, Skagit, and Port Susan Bay. While most of the dry land within this region is protected from inundation by sea dikes, the marshes and beaches on the bay edge will be trapped against sea-walls without space to move upwards in elevation.

Freshwater hydrology is hypothesized to be impacted by climate change, with lower low flows in the summer growing season due to reduced snowpack resulting in greater salinity intrusions into the estuary. Water level loggers will assess salinity changes which can be correlated to freshwater input via precipitation and runoff and thus the total sum of water levels within the salt marsh will include tidal and freshwater inputs. Tidal lows and highs within the salt marsh estuary will be quantified throughout the estuary.

Projected increases in flood and storm frequency may alter disturbance regimes. Duration and scale of tidal and storm inundation levels can be further modeled and correlated with

## Anadromous Fishes

The Stillaguamish watershed is the fifth largest tributary draining into Puget Sound.

The 700 square miles and approximately 3100 miles of stream length are home to multiple species of anadromous fishes. These species include two populations of listed Chinook (North Fork and South Fork); Stillaguamish and Deer Creek coho; North Fork and South Fork pink and fall chum; South Fork, Deer Creek, and Canyon Creek summer steelhead, coastal cutthroat, and Stillaguamish bull trout.

Land use in the portion of the watershed inhabited by salmon is 61 % forestry, 22% rural residential, 15 % agricultural and 2 % urban.



Chinook



Coho



Chum



Pink



Steelhead



Bull Trout

From:  
[www.sharesalmonstrategy.org](http://www.sharesalmonstrategy.org)

marsh elevation, sediment accretion, and vegetation characteristics to incorporate the accumulation of organic and inorganic inputs. Model outputs can assess potential available refugia under different tide heights and extremity of storm events, which can serve as a proxy for sea level rise.

Potential biota changes such as new species invasions or changes in the roles of existing species are also a threat of climate change. One hypothesis for the Port Susan region suggests that the snow goose population may be enhanced as the winter population shifts northward, away from the Central Valley of California and into the Salish Sea which would in turn increase their effects as ecosystem engineers while foraging on salt marsh vegetation.

Long term impacts of rising sea levels will affect rates of inundation and amounts of salinity that may lead to shifts in plant communities or vegetation mortality. Thus, it is important that organic and inorganic inputs are sufficient such that marsh accretion will outpace sea level rise. Additionally, biophysical changes expected in coastal ecosystems include changes in seasonality, phenology, climatic events, precipitation, ambient temperatures, water temperatures, acidity, salinity, and sea level rise (IPCC 2007). Sea level rise has averaged 1.8mm/yr from 1961 to 1993 and 3.1mm/yr since 1993, resulting in projections of 18-60 cm increases from 1990 to 2100 (IPCC 2007). However, recent predictions that incorporate the rapid melting of polar ice suggest that a 0.3-1.9 m increase is more likely (Jevrejeva et al. 2006, Jevrejeva et al. 2008, Vermeer and Rahmstorf 2009). Such large changes in sea level rise will have far-reaching effects on most coastal plant and animal species.

## 5.2 Hydrology and Sediment Dynamics

The restoration of tidal flow is likely to change the hydrodynamics of the adjacent nearshore environment. The resulting changes in water levels, flow, salinity levels, and sediment transport are the main physical drivers of biological responses, such as plant community colonization (Yang et al 2010). Characterization of hydrologic conditions primarily focuses on tidal regime, including the magnitude, frequency, duration, timing, and duration of inundation. Hydrologic analyses characterize

seasonal and inter-annual variation changes over time, as well as how it may change in the future under projected scenarios for climate and land use change. Understanding changes in the tidal regime is a crucial element in sediment transport and the development, extent, and sustainability of marshes and subtidal habitat types. However, key uncertainties include natural, seasonal, and annual variability, the interactive processes of sediment erosion-deposition-transport, future impacts of land use change, climate change, model uncertainty, and biological interactions and feedbacks in marsh sustainability (i.e., vegetation inundation and salinity tolerances and effects of widespread plant herbivory), and the effects of extreme events on channel formation and sediment transport.

One of the key uncertainties is sedimentation rates and the resulting influence on habitat development. Sedimentation and scour patterns can change elevations and are the main drivers of vegetation dynamics. Soil condition (i.e., soil texture, organic matter content, and nutrient availability) are also key determinants of vegetative growth and thus habitat quality. For example, a mitigation marsh with coarse sandy substrates and low organic matter content resulted in a vegetation canopy too short to support breeding habitat for the endangered light-footed clapper rail (*Rallus longirostris levipes*; Zedler 2005). Boyer and Zedler (1998) conducted scientific experiments and determine that soil amendments and nutrient enrichment were insufficient to ameliorate the effects of the coarse sandy substrates. They concluded it would take more than two years with nutrient and soil amendments for the restoration to progress and sustain an appropriate vegetation height for nesting rails (Boyer and Zedler 1998). Specifically, within the PSB restoration site, the soil within the diked area is likely quite different than native marsh soil. Several decades of farming may have resulted in a loss of organic matter, compaction, and an absence of new mineral inputs. However, the site has not been farmed for 10 years and a pond has recently developed, and thus the soil may have experienced some recharge.

### 5.3 Faunal Response

The Port Susan Bay restoration project will restore several physical processes such as re-establishing tidal flow and habitat connectivity to the previously diked parcel. These actions will create the opportunity for juvenile Chinook and additional fish species to access the habitat types in Port Susan Bay during all or part of their life cycles. The restoration will also increase available foraging habitat for migratory bird species that utilize Port Susan Bay nearshore environments and marshes. As the project is restored to an estuarine condition, the project site will also contribute to the region's capacity to produce food resources for Chinook salmon, waterbirds, and other wildlife.

For highly migratory species, such as shorebirds and anadromous fishes, a key uncertainty are the confounding factors occurring outside the basin that may limit species responses to the restoration, and which we have no control over. For example, a goal of restoration may include increasing populations of migrating birds. However, birds can be affected by actions occurring on the breeding grounds or at other locations on the flyway. Thus, an increase of high quality habitat at the restoration site may not improve populations.



## Cultural Resources

Natural resources are culturally important to the three Tribes of Port Susan Bay: Swinomish, Stillaguamish, and Tulalip

"The river is alive. It is an essential part of our lives. When it is vibrant and healthy, our well-being is preserved. We must heal and protect this precious resource, not just for our own tribal treaty rights, but because it's a wise and respectful thing to do for everyone who lives here."  
– Stillaguamish Tribe

The Stillaguamish and Tulalip tribes have been working toward the designation of Port Susan Bay as a Marine Stewardship Area since 1998.

The vision of the Tulalip Tribe Wildlife Section is, "To work cooperatively with the State and set an example for other tribes in the field of wildlife management and conservation...and to ensure that species become and remain sustainable for future generations"

The mission of the Stillaguamish Tribe Wildlife Program is: "The conservation of fish, wildlife, and plants and their habitats within the Stillaguamish Watershed."



[www.swinomish-nsn.gov](http://www.swinomish-nsn.gov)  
[www.stillaguamish-nsn.us](http://www.stillaguamish-nsn.us)  
[www.tulalip-nsn.us](http://www.tulalip-nsn.us)

## 5.4 Watershed Land Use Change

In 2000, the total population of the 12 counties surrounding Puget Sound was just under 4 million. The State Office of Financial Management currently predicts that those same 12 counties will grow to 5.5 million by 2025. At this rate, the region's overall population will likely double in the next 50 to 100 years (Lombard and Johnson 2010). Snohomish and Skagit Counties, housing Port Susan Bay and the Stillaguamish Watershed, are experiencing rapid growth. The population of Snohomish County, 711,100 in April 2010, has increased by 17.3% since 2000. The 2025 population forecast for Snohomish County is 909,453, a 27.9% increase over the next 15 years (Snohomish County 2010). Skagit County, with an estimated population of 119,534 in 2009, has experienced a 16.1% growth increase since 2000 (U.S. Census Bureau 2010). Once one of the slower growing counties in the region, Skagit County is now one of the fastest, whose population is predicted to increase by 100,000 over the next 50 years (Lombard and Johnson 2010). The high rate of population growth will affect Port Susan Bay in many aspects, the degree to which is uncertain.

With increased growth, land use within Skagit and Snohomish Counties is changing. Both counties support strong agricultural communities, diverse forested lands ranging from national park and wilderness areas to industrial forests and small rural forestlands, and 347 miles of marine shoreline (Lombard and Johnson 2010, Snohomish County 2002). These counties face difficult decisions over the coming years to continue to protect environmental values, maintain natural resource industries, and support livable and economically vibrant communities (Lombard and Johnson 2010)

## 6 OPPORTUNITIES AND CONSTRAINTS

### 6.1 Ecosystem Services for Communities and Stakeholders

#### 6.1.1 Flood Management and Infrastructure

Flooding in nearby low-lying areas results from a combination of coastal flooding and fluvial (rainfall-runoff) discharges. From a flood-management

perspective, there are three ways this project may reduce flooding vulnerability in the community: reducing inundation periods, increasing channel-flow conveyance and increasing floodplain capacity. The restoration project includes the construction of a flood relief valve in the dike which will speed the evacuation of floodwaters off of adjacent farmland during major floods and reduce the likelihood of sea dike breaches due to floodwater. Vulnerability during smaller floods may be reduced in the lower river reaches by the restoration project itself. Expanding the tidal floodplain increases the tidal prism. This increase in tidal prism results in greater flow energy to scour nearby channels, enlarging them and increasing their capacity to convey floodwaters. In addition, the increase in tidal floodplain area increases the volume of water that can be conveyed, which may reduce in-channel water surface elevations upstream.

### **6.1.2 Public Access and Recreation**

The restoration project has the opportunity to review the benefits of public access that will be compatible with restoration, wildlife, and habitat goals. Early phases of estuarine habitats can be sensitive to perturbations and public access may not be a realistic option for some areas. However, monitoring can provide information to adaptively assess levels of public access and impact on a developing ecosystem.

At this time, the nature and extent of public access post-restoration has not been determined, but may be limited by the fact that much of the new dike will not be owned by TNC. The potential for public access will also be dependent on future funding for facilities and staff capacity. With those caveats, public access such as walking on the levee can provide wildlife-viewing access, environmental education and interpretation, and other recreational uses to involve local stakeholders in the restoration process and increase land stewardship. The strategic placement of limited access trails, viewing platforms as well as key signage, and interpretive displays provides opportunities to foster ecological understanding, promote partnerships, and land stewardship. Some examples of interpretive themes include displays or signage of the history of the land and the restoration effort including the importance of habitats for certain species, such as juvenile Chinook.

Volunteer programs for habitat restoration, birding, and other field activities can promote community involvement within the restoration process. Historic land and water use such as waterfowl hunting contribute to the overall understanding of the past and how the landscape has changed over time. A key constraint for public access and recreation is the compatibility with wildlife and restoration goals. The presence of humans and dogs can lead to wildlife disturbance; however, careful designs can help minimize human impact.

### **6.2 Research Opportunities**

Opportunities for complementary research exist, some ideas include:

- Effects of snow goose herbivory on marsh formation and organic accretion rates (exclosures)



- Organic exports into the bay following restoration (current plants dying, moving out), detritivore food web, expecting flush on invertebrate production
- Sources of sediment inputs- size class of sediment in river and bay
- Methodological comparison of Heatwole (2006) vegetation sampling protocol with standardized marsh vegetation sampling
- Experimental plots for invasive species management.
- Juvenile Chinook residency times; otolith analyses for Chinook (See Lind-Null et al. 2008a, Lind-Null et al. 2008b, Lind-Null et al. 2009)
- Impacts of restoration on flood attenuation
- Hydrodynamic sediment transport model (HST)
  - Particle size fractionation samples
  - Utilize salinity and temperature profiles collected with water quality sondes

### 6.3 Site Specific Constraints

Project specific constraints include the implications of setting the dike back rather than removing it altogether. The setback will continue to affect the free expression of tidal processes such as subsidence or the colonization and persistence of invasive species. Additionally, removing the dike from its current location will affect the monitoring protocol. Currently, the dike allows the entire site to be accessible along the perimeter. Post-construction, access to the bay-side locations of the project will be limited by tidal inundation.

---

*“Ecosystem dynamics unfold into the future but are understood by examining the past” Carpenter 2000*

---

## 7 MONITORING APPROACH

### 7.1 Why Monitor?

Monitoring has been described as the financial equivalent of accounting, and is critical for project evaluation (Lee 1993). Monitoring and evaluation are fundamental aspects of assessing implementation strategies. Monitoring provides information on restoration progress and program effectiveness, provides a measure of accountability, and improves understanding of action-based results that are needed to further adaptive management and decision-making.

The intent of this monitoring plan is to develop methodologies to document long-term estuarine ecosystem responses to land use and climate change, and to evaluate the individual and cumulative impacts of conservation efforts occurring at multiple scales. The dike removal scheduled for 2012 represents an opportunity to test management hypotheses regarding habitat restoration, gather data before and after restoration impacts

are implemented, quantify the effectiveness of conservation actions, and inform future adaptive management.

In order to increase the likelihood of achieving restoration goals, there remains a great need for monitoring and adaptive management, which could serve to inform management decisions in a timely manner, determine if actions are having the intended outcome, and allow interventions when unexpected changes occur. Monitoring data are needed to compare with pre-restoration conditions, project long-term outcomes of management and the effects of climate change, communicate with interested parties, and to improve knowledge of coastal adaptation and resilience. Strategic monitoring provides accountability, additive learning, adaptation, and improved understanding to inform management-policy and the collective restoration community. However, even the most strategically planned restoration program can yield surprising and unexpected results (Zedler 2005). The cumulative effects of restorations may have synergistic, additive, unknown, or immeasurable results (Johnson 2007). Long-term science-based monitoring can be a strong tool in addressing these key uncertainties.

Consistent pre- and post- restoration monitoring are crucial components to immediately identify when and how a project may require external assistance or a shift in management procedures. As such, it is critical to expect the unexpected and be ready to adapt to the shifting mosaic that is a restoration site. In order to determine whether we are successfully making progress towards our long term goal, we need to understand how the estuary is responding to our actions and to ongoing threats and climate change.

The dike removal project at PSB is based on hypotheses developed as a result of baseline assessments, monitoring, modeling and literature review. Our current knowledge base leads us to suggest that:

- the large majority of historical estuarine marsh and channel habitat has been lost due to conversion to agriculture and to alteration of hydrodynamics as a result of the levee and dike system
- the levee and dike system on the lower Stillaguamish River have altered hydrodynamics, leading to:
  - a main river channel that acts like a pinched hose, carrying greater energy that propels freshwater, sediment, large wood, nutrients, fish, and other materials past the historical estuary and into the deeper waters of the bay much more rapidly than natural, and
  - secondary distributary and blind tidal channels with reduced energy that result in less scouring, more sedimentation and subsequent loss of channel area and complexity
- estuarine emergent marshes have continued to disappear over the past 40 years, likely as a legacy of the altered hydrodynamics and resulting loss of productivity
- local sea level has been rising, likely increasing the pressure on marshes
- removal of TNC's dike at the river mouth will restore tidal marsh habitat on the project footprint and also slow or reverse the trend of marsh loss by restoring some

of the natural distribution of hydraulic energy, freshwater, sediment, large wood, nutrients and other materials.

In order to determine if dike removal will successfully restore habitat and estuary-scale ecological processes, monitoring is necessary. Monitoring will allow us to determine whether further adjustment to the project is needed in the future, and will also inform future decisions regarding additional restoration actions and their appropriate location and design.

---

*“In an era in which the adverse economic and ecological consequences of environmental degradation are increasingly unacceptable, restoration ecology is emerging as one of the most important disciplines in the whole of environmental science” (Ormerod 2003)*

---

## 7.2 Adaptive Management

Adaptive management is the process of testing our management hypotheses, measuring the response of the ecosystem, and altering our management based on the new knowledge. Adaptive management is a process to assist individual restoration projects in achieving their objectives (Zedler and Callaway 2003). Our management and stewardship actions at PSB are based on hypotheses, whether explicit or implicit, that those actions will lead to achieving our long term ecological goal of restoring a functional estuarine ecosystem that is resilient to ongoing threats and adaptable to climate change.

Monitoring information will be used to assess whether program objectives are being met and whether hypotheses are supported. If program objectives are not being met, monitoring data are important in determining what adaptive management measures need to be taken. Intensive monitoring post-restoration will ensure that estuarine responses are recorded and problem areas are attended. Data will be analyzed to identify uncertainties in restoration progress and to determine if project goals are being met.

Some examples of events triggering Adaptive Management Actions could include:

1. Colonization of invasive species in the project site or the spread of an established invasive species such as *Spartina* post-restoration
2. Sediment accretion impeding full tidal inundation and evacuation
3. Formation of new distributary channels threatening neighboring properties
4. Levee armoring and structural integrity
5. Functionality and placement of flood gate

### 7.3 Before-After Control-Impact Design

The overarching goal of the proposed monitoring plan is to assess status and trends of physical and biological responses to restoration actions. Thus, we propose a BACI (Before-After, Control-Impact) sampling framework (Stewart-Oaten 1986, Stewart-Oaten et al. 1992, Underwood 1992, Stewart-Oaten 2003) to structure the monitoring. The BACI concept is to examine the *Before* (pre-construction baseline) and *After* (post-construction) condition of the area, as well as to compare a *Control* (reference site) with the *Impact* site (restoration site). *Before* and *After* sampling will determine how the restoration process changed the site through time from its historic condition. *Control* and *Impact* sampling will allow effects of restoration actions to be discerned from natural variability, stochastic events, and underlying trends in the larger area – for example, sea level rise increasing water levels on most areas within Port Susan Bay. A *Control* site which has identical conditions to the *Impact* site is not typically available. Thus, we use the term *Reference* site (see Smith et al. 1993) to describe areas near the restoration but not part of the area directly affected by the restoration project. The restoration and reference sites are typically monitored with similar intensity to allow for direct comparison of the different monitoring samples.

#### Baseline Data

Baseline data define the current condition of the community or population of interest and provide a basis with which to compare the responses of the system to future restoration actions. Baseline data collected at the restoration site and reference marsh provide a means to differentiate responses due to dike removal from natural stochastic variation.

Existing baseline data within Port Susan Bay includes LiDAR data from 2005 (TNC unpublished data), hydrodynamic model (Dunwiddie et al. 2009), a Sea Level Affecting Marshes Model for Port Susan Bay (Clough and Larson 2010), predicted vegetation communities (Yang et al. 2010), aerial photography, aerial bird surveys (TNC unpublished data), area bird counts (Slater 2004), farming for wildlife bird surveys (Slater and Lloyd 2010), channel cross-sections measured in 2004, habitat characterization and mapping collected estuary-wide at 224 locations in 2004 and 2005 (Heatwole 2006), and water level data collected in 2005 (Table 3). The Stillaguamish Tribe has conducted fish and water quality surveys in the region (Collins 1997, 2000, ST NRD 2009), as well as a nearshore and delta habitat map of Port Susan Bay (Griffith 2005).

#### Reference Marsh

Long-term data collected *Before*- and *After*- restoration actions and at a reference marsh are crucial to evaluating the restoration process and verifying predictive tidal marsh restoration models (Roman et al. 2002). A reference marsh serves as a model trajectory for the restoration site. Reference marshes should have a minimal history of anthropogenic disturbance and include the presence of desirable characteristics such as native plant communities, high species richness, presence of rare species, and valuable natural resource products (Zedler 2005). The reference marsh selected for the Port Susan Bay restoration project is owned by TNC and is located south of the restoration site (Figure 1).

## 7.4 Monitoring Stations

Monitoring stations are locations within the project site where several biophysical samples occur within a small area. Monitoring stations are cost-effective, time-efficient resources because they reduce travel time across the project, minimize access procedures and disturbance to sites, and facilitate the ease of relating complementary datasets during analyses. Each monitoring station in Port Susan Bay will represent a site of intensive monitoring. When possible, baseline sampling locations should be used as monitoring stations and locations. At the minimum, monitoring stations will include elements of the following monitoring categories: Landscape, Elevation, Hydrology, Sedimentation, Habitat, and Fauna.

## 8 MONITORING GROUPS AND METHODS

Estuarine restoration often involves restoring a suite of dynamic processes that can lead to shifting mosaics of wetland habitat types. This shifting habitat mosaic is largely driven by both spatial and temporal variability in physical attributes and their interactions with biological processes. It is because of these inherent changes that we focused on developing a hypotheses-driven monitoring framework which is structured by restoration objectives and includes a predictive model to be tested or developed, restoration target, performance metric, and monitoring group (Table 1). Within Table 1, the monitoring group column forms the direct link to the methodologies to use to address restoration objectives and hypotheses. Furthermore, for each monitoring group we outlined specific monitoring techniques, recommended frequency of sampling, range of sampling density, estimate of effort for each survey type, and ultimately linked these metrics to the Port Susan Bay conceptual ecosystem model (Figure 2) by distinguishing which methods addressed changes in ecosystem structure, process, or function (Table 2). Though initial recommended range of sampling numbers (Figure 2) were based on field experiences and restoration expertise, the actual number of samples and sampling locations will need to be determined in the field based on site-specific conditions.

Ecosystem structure is the major habitat unit in the system (e.g., emergent marsh, mud/sand flat; Thom et al. 2004). More specifically, ecosystem structure consists of three components: the composition of the biological community including species, numbers, biomass, life history, and spatial distribution of species; the quantity and distribution of abiotic materials such as water and nutrients; and the range of physical conditions such as temperature, water levels, and topography (Odum 1969).

Ecosystem processes and functions are the dynamic attributes of ecosystems, including interactions among organisms and interactions between organisms and their environment. Ecosystem processes are the fundamental conditions and outputs of the ecosystem that can include biological, chemical and physical operations (Thom et al. 2004), which often refers to the mechanistic processes such as sedimentation or species colonization. Ecosystem functions are the products generated by the system that provide support for ecosystem sustenance and human needs (Thom et al. 2004) or the dynamic attributes which most directly affect metabolism, such as nutrient cycles and energy flux (SERI SPWP 2004).

The choice of monitoring methodologies is often dependent on many considerations such as: project goals, site and environmental conditions, existing condition, comparability to other projects, available staff and funds, and new technologies. Periodic evaluation of the spatial resolution, temporal frequency, and the data are essential in evaluating whether monitoring methods have captured restoration changes and addressed restoration goals and hypotheses. Furthermore, evaluation of the methods themselves is critical to ensure the efficacy of monitoring tools and approaches, especially as environmental conditions change, with programmatic changes in monitoring effort, or as technologies improve. Specific Standard Operating Procedures (SOPs) have been developed for the Nisqually Delta Restoration program and other estuarine restorations are included in the Appendix for additional consideration and detail.

### **Qualitative vs. Quantitative Monitoring**

Qualitative monitoring often is described as a “lesser” form of monitoring, because it doesn’t cost very much and often doesn’t involve advanced technologies. Yet, many important restoration questions may be answered with by simple, systematic observation. Qualitative monitoring can play an important role in all wetland restoration projects, and in many projects, it may be sufficient to provide information on project results.

Quantitative monitoring becomes important when there are key uncertainties that need to be addressed, risks that need to be minimized, complex adaptive management choices that need to be made, or opportunities for regionally significant lessons that could change restoration practice. This monitoring plan attempts to strike a balance, focusing on qualitative monitoring where simple answers are sufficient or where the cost of quantitative monitoring exceeds the benefit to TNC’s mission. Quantitative monitoring will be focused on issues where more rigorous information is needed to document changes created by the restoration or when detailed learning opportunities inform the general practice of wetland restoration.

Table 2. Post-restoration monitoring sampling methods, variables, frequency, number of stations, and effort associated with each method. Monitoring methods are grouped by category and by the ecosystem structure, process, or function. The range of sampling numbers allows for field adjustments and is based on expertise and practical field experience.

Monitoring		Method	Variable	Frequency	Number of Samples			Effort		Structure, Process, Function
Group	Category				Estuary	Restoration Site	Reference Site	Cost	Labor	
<b>Elevation</b>	Remote Sensing	LiDAR	point cloud	once post restoration, then 3-5-yr	1	1	1	high	med	Structure
	Ground-based	RTK GPS	point elevation	6-yr biennial, then 3-5-yr	variable (100-250m spaced transects)	6-12 (50-100m spaced transects)	6-12 (50-100m spaced transects)	med	high	Structure
	Bathymetry	Echosounder	point elevation	5-yr annual, then 3-5-yr	variable (100-250m spaced transects)	6-12 (50-100m spaced transects)	6-12 (50-100m spaced transects)	med	med	Structure
<b>Habitat</b>	Subarea	photo-points	imagery	Annual	4-12	4-12	4-12	low	low	Structure
	Area	aerial photographs	% change	5-yr, semiannual, then 3-5-yr	1 (8-12 images)	1	1	med	low	Structure
	Communities	aerial photographs	area	5-yr semiannual, then 3-5-yr	1	1	1	high	med	Structure
	Vegetation	transect with quadrats, plot	% cover, stem density, mean height	Annual	6-24	6-18	6-18	low	med	Structure
	Large Woody Debris	aerial photographs	count	5-yr semiannual, then 3-5-yr	1	1	1	med	low	Structure
	Channels	cross-sections	width, depth	6-yr biennial, then 3-5-yr	variable	2-4 (2-3 X sections)	2-4 (2-3 X sections)	low	med	Structure
	<b>Hydrology</b>	Continuous Water Level, Temperature, Conductivity	continuous loggers	depth, salinity, temp	15-min, maintained bimonthly	2-6	1-4	1-4	med	low
Continuous Water Quality		continuous sondes	pH, salinity, temp, DO, turbidity	Continuous, periodic maintenance	1	1-2	1-2	high	med	Process
Discrete Water Quality		spot metering	salinity, temperature by depth	With logger maintenance	6-24 (3 reps)	6-18 (3 reps)	6-18 (3 reps)	med	low	Process
Nutrients and Primary Productivity		grab samples	concentration, chl-a	Seasonal	1-2 (2 reps)	1-3 (2 reps)	1-3 (2 reps)	low	med	Process
Hydrodynamics		ADCP	profile	Seasonal	variable	2-4	2-4	med	med	Process
<b>Sedimentation</b>	Accumulation	sediment pins	elevation	Semiannual	n/a	12-36	12-36	low	low	Process
	Sediment Elevation	SETs, Marker Horizons	elevation	Semiannual	2-6	2-4	2-4	high	med	Process
	Soil Characteristics	with cores	texture, grainsize	Annual	6-24	6-18	6-18	med	low	Process
<b>Fauna</b>	Terrestrial Invertebrates	fall out traps	index, biomass	Monthly, Apr-Aug	2-12 (3 reps)	2-8 (3 reps)	2-8 (3 reps)	high	high	Function
	Pelagic Invertebrates	neuston tows	index	Monthly, Apr-Aug	1-2 (3 reps)	1-4 (3 reps)	1-4 (3 reps)	high	high	Function
	Benthic Invertebrates	cores	count, biomass	Monthly, Seasonal	3-24 (1-2 reps)	3-12 (1-2 reps)	3-12 (1-2 reps)	high	high	Function
	Birds	area surveys	count	Quarterly, Monthly	1	1	1	low	med	Function
	Birds	circular plots	index, density	Breeding season	n/a	6-18	6-18	low	med	Function
	Fish	Fyke nets	index	Monthly, Apr-Aug	1-2	1-4	1-4	high	high	Function
Fish	beach seine	index	Monthly, Apr-Aug	1-2	1-4	1-4	high	high	Function	



## 8.1 Elevation

The geomorphology and topography of the estuary are main drivers of the composition and distribution of vegetated (as well as unvegetated) habitats. Elevation ranges and the spatial distribution of the topography, combined with hydrology and hydrodynamics determine the habitat availability for fish and birds access to intertidal habitats. In addition, tidal creeks and channels are an important drainage and habitat feature of tidal salt marshes. They influence biological and physical characteristics such as plant and avian distributions, fish and invertebrate establishment, and soil biogeochemistry (Callaway et al. 2001, Zedler 2001, Hood 2006, Hood 2007). Repeated measurements of LiDAR, topographic mapping, and bathymetry provide useful information regarding the development of geomorphic features over time. Elevation surveys will be conducted at regular intervals (at least every 3-5 yrs) and compared to pre-restoration elevations for a spatial analysis of change detection.

The goal of elevation monitoring is to quantify changes in topography and bathymetry that result from restoration, and to relate those changes to responses in hydrology, vegetation and fauna. All restoration objectives and hypotheses include components of measuring changes in elevation (see Section 4.3, Table 1): Objective 1 (Restoring self-sustaining tidal wetlands at site): H1.1, H1.2, H1.3, H1.4, H1.5, H1.6; Objective 2 (Improve fish access to site): H2.1, H2.2; Objective 3 (Improve connectivity in estuary): H3.1, H3.2, H3.3, H 3.4, H3.5; and Objective 4 (Improve flood attenuation in estuary): H4.1, H4.2.

### 8.1.1 Topography

Airborne Light Detection And Ranging (LiDAR) is an optical remote sensing technology that can be used to accurately georeference terrain features. In the Spring of 2005, LiDAR data was collected in the lower Stillaguamish River estuary and Port Susan Bay (Figure 4). Additional pre-restoration LiDAR is scheduled to be collected in the Spring of 2011. These acquisitions will provide the baseline elevation data before dike removal. LiDAR or other elevation data should be acquired post restoration and subsequently every five years to capture both the rapid and long term restoration changes across the landscape. LiDAR is a beneficial tool offering quick, broad scale collection of highly detailed terrain surface data. However, elevation is a critical controlling factor of marsh development and error rates of  $\pm 15$  cm (and recent studies suggest  $\pm 30$ cm in tidal marshes) have reduced utility in a tidal marshes where centimeters of change in elevation affect habitat development and vertebrate response (Woo et al. 2009, Athearn et al. 2010). Acquired LiDAR data should be ground-truthed using the data collected with the RTK GPS system and echosounder bathymetric system.

Ground-based topographic mapping using a real-time-kinematic global positioning system (RTK GPS) is a useful tool for collecting high resolution elevation data at the landscape level. RTK GPS is mobile, collects data quickly, and measures elevation within an accuracy of 1 – 3 cm. High resolution elevation data will be collected biennially for the first six years post construction based on a uniform grid distribution. Elevation points will be collected

with every 25 m along transects that are spaced 50-200 m apart, depending on the size of the site. Elevation points will be collected within the restoration site, reference marsh, and the estuary (Appendix 13.2).

## 8.1.2 Bathymetry

Underwater bathymetry compliments LiDAR and ground-based topographic mapping in inundated areas where LiDAR and RTK GPS data acquisition may not be feasible. Bathymetry uses sound navigation and ranging (sonar) technology to map seafloor terrain. Bathymetry will compliment LiDAR and ground-based topographic mapping by providing accurate elevation data in inundated areas throughout the Stillaguamish estuary. Bathymetric data are a critical component for hydrodynamic models and provide a background layer or 3-D surface for draping thematic maps such as benthic and marine organism habitats or geologic data (NOAA 2007). Deep and shallow water bathymetric data will be collected in conjunction with LiDAR and ground-based topographic mapping. Deep and shallow water bathymetry requires different boats and equipment for access and mapping.

Above-ground topographic (LiDAR or RTK GPS) data and bathymetric datasets should be combined and merged to create a single digital elevation model of the estuary. If possible, LiDAR data should be ground-truthed with an RTK GPS.

Surface Elevation Tables (SETs) paired with marker horizons have been used for highly accurate measurements (with millimeter accuracy) of elevation change to understand the processes driving elevation change (i.e. subsidence, sedimentation, etc.; see Sedimentation Section).

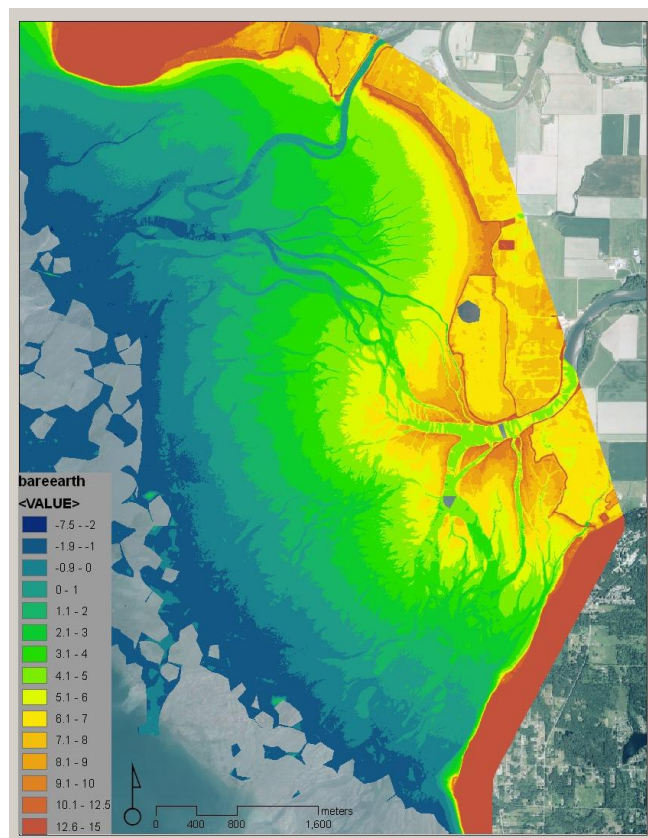

Figure 4. Spring 2005 LiDAR elevations (ft) for the Stillaguamish estuary.

## 8.2 Habitat

The distribution and spatial extent of habitat types are fundamental aspects of any monitoring plan. The goal of habitat monitoring is to quantify changes in the extent and distribution of habitat types that result from restoration, and to relate those changes to responses in hydrology, vegetation and fauna. Restoration objectives and hypotheses that include components of measuring habitat changes (see Section 4.3, Table 1) are: Objective 1 (Restoring self-sustaining tidal wetlands at site): H1.1, H1.2, H1.3, H1.4, H1.5, H1.6;

Objective 2 (Improve fish access to site): H2.1, H2.2; and Objective 3 (Improve connectivity in estuary): H3.1, H3.2, H3.3, H 3.4, H3.5.

### 8.2.1 Photo-Points

Photo-documentation with fixed, permanent digital photograph locations repeated over time is an economical method to provide a qualitatively way to visually assess changes in the landscape (Appendix 13.1). Photo-documentation is also a useful tool in communicating these changes to the public. Photographs can be coordinated with aerial photos and used to calibrate aerial photographs as well as track the development of vegetation communities, channel structure, and other metrics such as invasive plant reduction.

Digital panoramic photos (see [http://www.nisquallydeltarestoration.org/science\\_photo-documentation.php](http://www.nisquallydeltarestoration.org/science_photo-documentation.php)) will be collected at least annually at all monitoring stations and a few additional vantage points to provide large coverage of the site. Several factors should be considered when establishing the location and number of photopoint locations such as: site access for repeatability, the number of photopoints can be stratified to represent areas of interest (i.e., different habitat types, channel development, movement of large woody debris into the system), coordination with other surveys such as vegetation surveys and aerial photographs, coordinated with tide (extent of inundation during high tide or tidal evacuation during low tide), or to capture extreme phenomena (i.e., extent of inundation during king tide events).

### 8.2.2 Aerial Photography and Remote Sensing

Aerial photographs are the basis for remote sensing applications and are valuable tools for the visual documentation of water drainage, channel development, vegetation colonization, and geomorphic change. Initial acquisition should be prior to restoration and photographs should be acquired annually thereafter for the first five years to document initial site response after restoration. False color infrared aerial photos should be taken during low tide at the peak of the growing season. Approximately 8-12 photographs will need to be tiled together to cover the estuary. Ensure that the image tiles overlap by 20% to develop a mosaic with the aerial images. Registered targets or landmarks placed at monitoring stations can be used to geo-reference aerial photographs. Otherwise, request that the aerial photography company mosaic and georeference the images to save time and maintain consistency. Aerial images will be of consistent pixel resolution (the on the ground area that is represented by 1 pixel seen on the screen) so that changes seen in the aerial photograph are not due to changes in image resolution. Geographic Information Systems (GIS) software will be used to assess vegetated salt marsh coverage, digitize channels and assess channel development, and quantify spatial extent of land-cover types (with ERDAS Imagine or other software).

#### 8.2.2.1 *Habitat Types*

Habitat distribution will be assessed using infrared aerial photographs and spatial software (such as ERDAS Imagine and ESRI ArcGIS) to classify, delineate, and digitize boundaries for the key estuarine habitats. Habitat classifications for the Stillaguamish estuary have been

outlined by Heatwole (2006; Appendix 13.14) which include: (1) High Emergent wetlands (HE) which are generally characterized by *Agrostis* spp. (bentgrass), *Juncus balticus* (Baltic rush), or *Carex lyngbyei* (Lyngby's sedge). (2) Low Emergent (LE) wetlands, characterized by *Scirpus americanus* (American bulrush) or *Scirpus maritimus* (maritime bulrush). (3) Vegetated Tide flats (VT) which support <25% cover of emergent vegetation. (4) Unvegetated Tide flats (UT) which contain no emergent vegetation. (5) and eelgrasses (EG) which are commonly on the otherwise unvegetated tide flats and are characterized by  $\geq 25\%$  cover of *Zostera japonica* (Japanese eelgrass) (Figure 5). Prior to restoration, the wetland behind the diked area that developed in response to reduced pumping of rain and groundwater was distinguished from diked upland by the presence of emergent estuarine species, ponded water, or decaying terrestrial grasses. Habitat and community composition data collected during annual vegetation surveys (see Vegetation), as well as personal site knowledge will be used for ground-truthing and refinement of the spatial extent of each habitat classification.

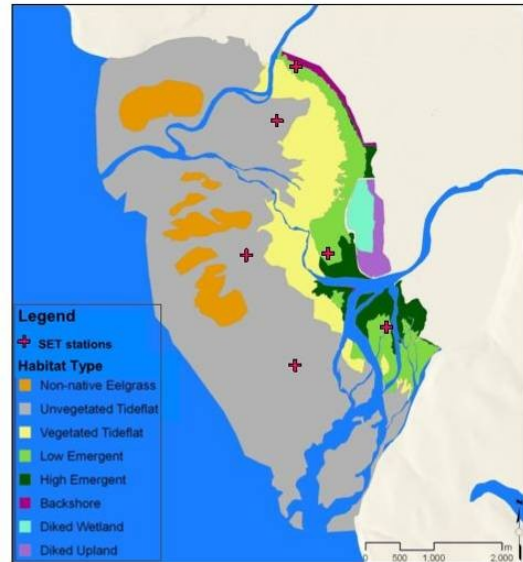

Figure 5. 2004-2005 habitat map for the Stillaguamish Delta. Surface elevation tables are approximate.

### 8.2.2.2 Channels

To document changes in channel allometry such as formation and movement, we will use the low-tide aerial photographs and ArcGIS to digitize the width and length of visible channels. For higher resolution channel mapping, the site may be mapped on foot using a GPS and additional channels will be further digitized and classified by channel order within ArcGIS. For comparisons between years, a consistent scale of resolution is necessary so that change detection is based on observed differences rather than different detection ability.

### 8.2.2.3 Large Woody Debris

Woody debris refers to fallen trees, logs, stumps, and root wads that can be transported from upstream sources and deposited within the estuary. Large woody debris (LWD) provides important habitat structure for fish and other estuarine species, and can change water flows, velocities, sediment transport. Furthermore, the decomposition of LWD can support significant invertebrate prey resources for fish and other aquatic species and provide channel and streambank stability in low gradient streams. Accumulations of LWD may form logjams that span the entire width of a channel. These natural occurrences usually do not impede fish passage, rather can create backwater conditions and pools that can be beneficial in creating new channels. LWD can be difficult to define because it largely depends on the habitat or hydrologic significance. Nonetheless the Washington Department of Ecology defines LWD as logs that are  $\geq 10\text{cm}$  in diameter and at least 1m long (Janisch 2006). However, to track the size and movement of LWD by digitizing them on aerial photographs, the size of LWD may need to be adjusted to a larger size class.



Large woody debris will be monitored with remote sensing from annual aerial photographs. Visible LWD will be located and delineated on a georeferenced image. The imagery will be analyzed to assess changes and movement associated with the location and functions of the LWD (i.e., log jam, creating pools reducing channel flow, facilitating new channel development). To best digitize LWD using aerial imagery, we will analyze high resolution aerial imagery.

### 8.2.3 Channels

A subset of digitized intertidal channels will be selected for annual cross-section data collection to assess 3D channel development and change. Channel cross-sections will be assessed annually for the first six years post restoration and then measured every five years. Intertidal channels should be stratified by habitat type and channel type (e.g. distributary, blind channel). Prior to restoration, non-tidal channels within the interior of the dike will be well mapped to document channel formation after dike removal (Appendix 13.3).

### 8.2.4 Vegetation

The current and changing composition and condition of the vegetation community influence the spatial distribution and use by birds, mammals, and fish. Vegetation compositions and condition indicates the extent and location of estuarine habitats. Vegetation monitoring will denote the presence and potential source populations for restored areas. Vegetation sampling, paired with aerial photography, habitat digitization, and elevation and bathymetric data will provide a project-scale temporal and spatial understanding of estuarine processes after restoration. In particular, coordinated sampling of vegetation with aerial photography can help with aerial photo interpretations of often complex habitats and land use characteristics.

Vegetation sampling will be conducted yearly at permanent monitoring stations during the summer months (July-September) when vegetative cover is at its maximum. Vegetation surveys use a combination of point intercepts, quadrats, and circular habitat and land use plots to best characterize community composition and structure across a gradient (Appendix 13.4). Vegetative composition, height, and percent cover of plant species will be collected in order to assess changes in vegetation through time. In addition, pore-water salinity and soil texture samples will be collected (see Soil Characteristics section 8.4.3). Vegetation cover estimates should be conducted by the same person for each sampling event to maintain a consistent sampling protocol and minimize sampling bias and errors. Otherwise, each person will be trained for estimating plant cover for greater consistency amongst observers. Standardized protocol for sampling and mapping marsh vegetation



Juvenile Bald Eagle on large woody debris

may be scaled up or down increasing the feasibility of collaborating with partner datasets for regional assessments.

### 8.3 Hydrology

Hydrology and water quality are primary drivers of wetland processes (i.e., sediment transport and channel development), habitat structure (i.e., channel allometry and channel complexity), and ecological functions (i.e., nutrient circulation and food web support). Inundation regimes, in combination with elevations and sediment characteristics, are primary drivers of the vegetation and invertebrate community dynamics and also determine available access times for fish and bird communities. Water quality also an important determinant of habitat quality (for dissolved oxygen, temperature, conductivity/salinity, turbidity, pH, and chlorophyll *a*) for aquatic species.

Dike removal will allow for tidal exchange within the restoration and alter freshwater flows in the estuary (Dunwiddie et al. 2009). Dike removal will increase tidal prism and promote channel formation and habitat connectivity for aquatic species. Four methods are considered for hydrology and water quality monitoring: (1) continuous monitoring of water levels; (2) discrete water quality measurements; (3) continuous water quality measurements; (4) quarterly grab samples for nutrients and chlorophyll *a*; (5) flow and hydrodynamics. The Stillaguamish Tribe has conducted water quality sampling within Port Susan Bay and future sampling will be coordinated so as not to duplicate efforts (Figure 6).

The goal of hydrology monitoring is to quantify changes in water levels, water quality, and hydrodynamics that result from restoration, and to relate the changes to the estuary scale. All restoration objectives and hypotheses include components of measuring changes in hydrology (see Section 4.3, Table 1): Objective 1 (Restoring self-sustaining tidal wetlands at site): H1.1, H1.2, H1.3, H1.4, H1.5, H1.6; Objective 2 (Improve fish access to site): H2.1, H2.2; Objective 3 (Improve connectivity in estuary): H3.1, H3.2, H3.3, H 3.4, H3.5; and Objective 4 (Improve flood attenuation in estuary): H4.1, H4.2.

#### 8.3.1 Continuous Water Level, Temperature, Conductivity

Water levels measured at frequent intervals (such as 15-minute) provides information on the daily tidal fluctuations, extreme events, and seasonal variation in water levels. Water level loggers record data at user defined intervals and require periodic data download in the field. For example, at 15 minute recording intervals, water level loggers will need to be downloaded 4-5 times a year. Model 3001 LTC Levellogger Junior (Solinst Canada Ltd.) is a logger that records water levels, temperature and conductivity (later converted to salinity; Appendix 13.5). A separate barometric data logger that measures the local air pressure is required to correct water pressure readings to water levels. Surveyed staff gages will be installed with each logger so that readings can be converted to a vertical datum (NAVD88) and the logger can be checked for drift over time. Water level, temperature, and conductivity loggers with a referenced staff gage (LTC station) provide a means to track changes in the key water quality parameters identified for the estuary.



Based on the design of the hydrodynamic model of the bay in 2005 (Yang 2010), LTC stations in the two main river distributary channels will document the frequency and duration of tidal flooding and characterize water quality parameters at the estuary scale. Three to four additional LTC stations will be placed in the tidal marshes and tidal flat in order to capture inundation and salinity regimes.

A permanent, fixed, continuously operated tide station in Port Susan Bay would provide valuable information for long term data trends and comparisons to local site conditions. One LTC station will be established at the river mouth in Hatt Slough. It should be located no farther upstream than the temporary station installed in 2005 for development of the hydrodynamic model (48° 11.8095' N, 122° 21.9857' W). The other LTC station will be installed in South Pass, in the general vicinity of the temporary 2005 station (48° 13.5778' N, 122° 23.1410' W). Ideally, each monitoring station would be located within survey range of a local elevation monument. Water level and quality data will be recorded at 15 minute to 1hr intervals.

LTC stations will be located at SET (See Sediment Elevation Table Section 8.4.2) locations and/or monitoring stations where a suite of other physical and biological measurements will be made so that inundation regimes can be closely tied to changes in vegetation, sedimentation, and elevation. At least one logger will be located in the newly restored area, the adjacent tidal flats, and the reference marsh. If desired and costs allow, a remote logger system with near-real time data acquisition and displays may save considerable time. The data will be readily accessible and allow for quicker detection of logger malfunction and can be integrated with other instrumentation and real-time data (i.e., weather station).

Post processing of the data includes converting water level data to NAVD88 from staff gage readings. Water level data consists of a time series that can be plotted on a hydrograph to visually assess water levels over time (such as impediments to drainage) and between locations. Tidal range, mean maximum, mean minimum will be presented as summary calculations. In combination with elevation data, inundation times and percents can be calculated to provide the amount of time areas of interest (i.e., restoration site, marsh) are accessible to fish or specific waterbird guilds.

### **8.3.2 Discrete Water Quality**

Water quality spot readings for turbidity, salinity, conductivity, temperature, dissolved oxygen, and pH will be recorded along a depth transect or at a fixed depth with a handheld water quality multi-probe in conjunction with invertebrate and fish sampling (Appendix 13.7) or when downloading LTC stations. Surface and bottom measurements will be collected to characterize water quality stratification if it exists.

For comparing water quality parameters both spatially and temporally, measurements will be collected at the same tide level (i.e. slack high water). Salinity and temperature profiles will be collected and compared with soil porewater salinities throughout the delta to test the hydrodynamic and vegetation model (Dunwiddie et al. 2009, Yang et al. 2010; Appendix 13.15).

### 8.3.3 Continuous Water Quality

Water quality parameters vary by time, tide, and season such that discrete measurements may not capture the full extent of variation that can influence biological processes. Continuous water quality sondes (such as Hydrolab or YSI multi-parameter water quality sondes) that include water quality parameters: conductivity, turbidity, dissolved oxygen, pH, (with Chlorophyll *a* option, see Nutrients and Primary Productivity Section 8.3.4) will be programmed to record at 15 minute intervals.

Water quality sondes will be deployed at the mouth of Hatt Slough and within the restoration footprint (Appendix 13.6). Water quality sondes will be deployed at the same locations as water level loggers. In addition, deployment will be coordinated with flow measurements to better understand circulation and water movement in the estuary.

### 8.3.4 Nutrients and Primary Productivity

Nutrients are essential for sustaining marine ecosystems. However, when nutrients, especially nitrogen, are present at excessive levels, eutrophication can occur, leading to algal blooms and oxygen depletion. Anthropogenic sources of nutrients to the Stillaguamish estuary include agricultural and stormwater run-off, groundwater seepage, and atmospheric deposition. Nutrient monitoring is an important tool for investigating patterns and drivers of change in nutrient concentrations and can be used in adaptive management decisions for mitigation and remediation strategies (Kennish 2003, Kennish and Townsend, 2007). Chlorophyll *a* concentration is generally proportional to the amount of phytoplankton, and therefore the overall productivity of estuarine waters and can often be linked to nutrient concentration (Objective 1: Restoring self-sustaining tidal wetlands at site: H1.6).

Nutrient and chlorophyll *a* concentrations will be measured quarterly at each water level logger station or continuously logged with a multi-parameter water quality logger. Nutrients measured will include: dissolved inorganic nitrogen ( $\text{NH}_4^+$ ,  $\text{NO}_3^-$ ,  $\text{NO}_2^-$ ), orthophosphate ( $\text{PO}_4^-$ ), total nitrogen (TN), total dissolved nitrogen (TDN), total phosphorus (TP), and total dissolved phosphorus (TDP). Nutrient and chlorophyll *a* is measured monthly by the Padilla Bay National Estuarine Research Reserve located less than 40 kilometers away. To better compare these data to those collected at Port Susan

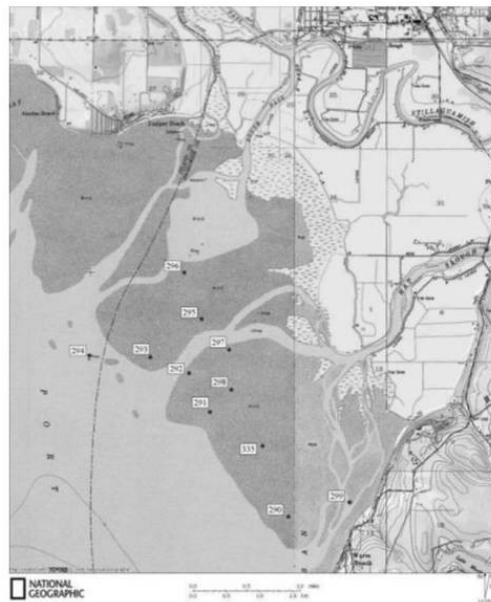

Figure 6. Water quality monitoring stations of the Stillaguamish Tribe.

Bay, the National Estuarine Research Reserve System's standardized sampling and quality control protocols should be followed (NERRS 2002, 2004).

### 8.3.5 Hydrodynamics

Physical processes in estuaries such as inundation, salinity variation, and water circulation patterns are dynamic. Along with freshwater inputs, the rise and fall of tides are the medium of energy exchange in estuary systems. River and tidal currents carry nutrients and sediment, create elevational and salinity gradients, and provide access to the marsh for fish and other aquatic organisms. To examine the processes that affect transport and mixing of these waters and particulates in the estuary, Acoustic Doppler Current Profilers (ADCP) may be deployed at select water level monitoring stations. The ADCP will be used to measure water levels, current velocities and directions and particulate backscatter throughout the water column. ADCPs can be costly to purchase, but may be more economical to rent for peak sediment transport periods during winter flood events.

## 8.4 Sedimentation

The rate of sediment accretion or erosion is a primary determinant of tidal wetland sustainability with sea level rise and a primary driver of habitat evolution over time. Habitat restoration at sufficient scale has the potential to modify sediment accretion or erosion patterns. Accretion rates vary spatially due to many factors including elevation, vegetation type and productivity, distance to channels, wave climate, and salinity dynamics. Elevation of the mud flat and the associated inundation frequency and duration are critical to understanding the potential vegetation community that will colonize post restoration actions. In the context of climate change, long term adaptability of tidal marsh depends in part on sediment sources, quantities and distribution patterns. Basin scale restoration and enhancement projects, including the blocking of large naturally eroding bluffs, are projected to significantly reduce historical sediment delivery rates. In contrast, changes in the flow regime and in storm frequency and intensity may increase sediment delivery. Three related approaches to characterize accretion rates will be used within and among habitat types: (1) elevation surveys (see Elevation 8.1), (2) sediment pins to assess large scale processes, and (3) Surface Elevation Tables (SETs) paired with horizon markers to track high resolution changes in elevation and be able to separate above ground and below ground processes.

The goal of sediment monitoring is to quantify changes in sedimentation and soil characteristics that relate the changes in elevation, vegetation, and invertebrates. The restoration objectives and hypotheses that include components of measuring changes in sediment (see Table 1) are: Objective 1 (Restoring self-sustaining tidal wetlands at site): H1.1, H1.2, H1.3, H1.4, ; and Objective 3 (Improve connectivity in estuary): H3.1, H3.3, H3.5.

### 8.4.1 Accumulation

Permanent depth poles or sediment pins (Takekawa et al. 2002, Woo et al. 2007) will be placed across the marsh plain to measure sediment accumulation or loss over time. Sediment pins are a cost-effective method and relatively quick way to measure

## Surface Elevation Tables and Marker Horizons

A Surface Elevation Table (SET) is a method to mechanically measure changes in surface elevation within a wetland ecosystem (Cahoon and Lynch 2003). SET tables are commonly paired with marker horizons to quantify surface deposition and erosion. Used together, SET and marker horizons can provide information on the processes occurring below ground that are influencing elevation change.

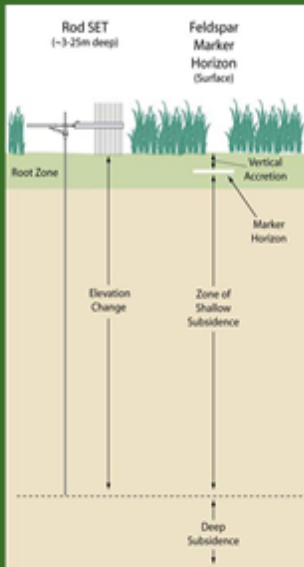

Figure from:  
<http://www.pwrc.usgs.gov/set/theory.html>

sedimentation rates on a large spatial scale. They can also provide a “spot check” for LiDAR, bathymetry, and ground-based topographic elevation surveys. Each pole will be surveyed to NAVD88 so that the elevation of the sediment surface can be calculated by pole height. As sediment accretes, the length of the exposed pole will decrease and vice versa (Appendix 13.8). Spatial distribution of sediment pins should be representative of the topography, expected habitat development, and water flow dynamics within the estuary. For example, sediment pins will be placed along permanent vegetation transects to better compare sedimentation rates and elevation changes to vegetation colonization and community composition. Sediment pins will also be coordinated with SET measurements to better compare sedimentation rates between methods and across the landscape, and placed within the estuary to examine sedimentation rates amongst different habitat types.

### 8.4.2 Sediment Elevation

Surface Elevation Tables (SET) provide a method for making accurate and precise measurements of surface elevation relative to a fixed subsurface datum. When paired with marker horizons, the SET can offer information on below ground processes driving elevation change (i.e. subsidence, uplift, etc; Cahoon and Lynch 2003). SETs will be used to accurately measure elevation changes in two habitat types and three geographic regions of the estuary (Figure 3).

One modified, deep-Rod SET will be installed in low-elevation emergent wetlands and unvegetated tide flats in each of the following areas: south of Hatt Slough, north of Hatt Slough, and south of South Pass. Additional SETs are recommended in each of the expected habitat types within the restoration site.

Baseline elevation measurements will be taken after a two week settling period following installation, based on the instructions available at <http://www.pwrc.usgs.gov/set/>. Elevation data will be recorded during low tides twice per year (in April and October) for the first three to five years, and once per year thereafter. We recommend that SET readings be taken on the same instrument by the same person for each sampling event, to maintain a consistent sampling protocol and minimize sampling bias and errors.

Marker horizons will be coupled with SET monitoring stations to assess the variability of accretion rates within habitats relative to ground surface elevations. For emergent wetland (and potentially vegetated tide flat) habitats, 50 x 50 cm feldspar marker horizons will be installed. Accretion measurements will be made either by cutting out a sediment plug, or for inundated soft sediment, using liquid nitrogen to freeze the sediment plug before removal. For tide flat and eelgrass habitats, we will use 30 x 30-cm squares of plastic grids for fluorescent lights (J. Rybczyk, pers. comm.). The grids will be pressed down into the sediment until they are level with the ground surface, and then topped with a layer of feldspar clay.

Detailed instructions for SET and feldspar marker horizon installation and measurement are available on the USGS Patuxent Wildlife Research Center Surface Elevation Table website (<http://www.pwrc.usgs.gov/set/>).

### 8.4.3 Soil Characteristics

The physical properties of soil (i.e. particle size fractionations) are important aspects of sediment transport models. In addition, soil attributes (i.e., soil texture, nutrient availability, and organic matter content) are key determinants of vegetative condition, invertebrate response, and avian foraging responses. Soils collected at strategic monitoring locations will provide information for models or biological responses. A known volume of soil can be sent to a laboratory to analyze for percent sand, silt, and clay or particle size fractionations, soil organic matter content, and nutrient availability. Observed changes in the vegetation community can be a result of soil salinity, especially in areas where specific species tolerances are near thresholds for growth. Pore-water soil salinity will be collected separately and measured in conjunction with salt marsh and tide flat vegetation surveys (Appendix 13.4). Sample volume, collection, and storage methodology will be dependent upon desired analyses and laboratory specific guidelines.

## 8.5 Fauna

Estuarine invertebrates, fish, and birds are target communities that are expected to benefit from the restoration and increased connectivity in the estuary. The goal of monitoring for fauna is to quantify changes in invertebrate prey resources for fish and birds that result from the restoration, and to relate the changes to the species composition and abundance of fish and birds. The restoration objectives and hypotheses that area addressed by fauna monitoring are (see Table 1): Objective 1 (Restoring self-sustaining tidal wetlands at site): H1.4, H1.5, H1.6; Objective 2 (Improve fish access to site): H2.1, H2.2; and Objective 3 (Improve connectivity in estuary): H3.3, H3.4.

### 8.5.1 Invertebrates

Although invertebrate indicators are commonly monitored as a proxy for water quality, here we take an approach to examine invertebrates as key food resources for fish and avian predators. Fish consume a variety of prey items that fall into the water from the terrestrial environment, from within the water column, and from the benthos, while waterbirds have a varied diet depending on the avian guild. In general, snow geese feed on emergent marsh



vegetation, rhizomes and agricultural crop residue; shorebirds feed on benthic invertebrates; dabbling ducks feed on aquatic vegetation and invertebrates; and diving ducks feed on benthic invertebrates, aquatic invertebrates, and small fish. Since the monitoring focuses on invertebrates as prey resources, invertebrate identification to the lowest taxonomic level, although informative, may not be cost effective to answer questions based on prey resources. Rather, the taxonomic categories of interest should consider the known diet of predators of interest and their foraging modes or behavior.

Our goal is to assess the site capacity of the restoration to produce available prey resources for shorebirds and fish. Although there is some spatial overlap of habitat use by fish and birds their peak use are temporally distinct. Because of high spatial and temporal variability within the benthic infauna, invertebrate surveys will be conducted during peak waterbird use (Slater 2004), and coordinated with the Tribes for fish presence and use of Port Susan Bay (ST NRD 2009, Appendix 13.9). Benthic invertebrates will be sampled with benthic invertebrate cores, 10 cm diameter, 10 cm deep (as in Woo and Takekawa 2008). Samples will be collected, sieved and preserved then sent to a qualified invertebrate laboratory for sorting, identification, enumeration and weighing for dry biomass. Abundances will be standardized to area and reported as average density of invertebrates per m<sup>2</sup>. Cores will be sampled during months of peak waterbirds during the migratory season (Jul-April) and fish outmigration season (Apr-June), based on bird and fish surveys. Samples will be paired with soil samples for characterizing sediment properties such as particle size or soil texture, soil pH, organic matter content, and nutrients and point samples of water quality parameters (DO, water temperature, salinity). Benthic invertebrate sampling will occur at select monitoring stations within the restoration, reference, and delta study sites.

In addition to benthic invertebrates, juvenile Chinook diets are comprised of insects that fall into the water from the aerial environment (fall out traps) and neuston found within the top of the water column (neuston net; Simenstad et al. 2001, Gray et al. 2002, and Ellings and Hodgson 2007; Appendix 13.10 ). Invertebrate studies to quantify prey availability for fish will be coordinated with the Tribes for efficiency and resource sharing. Fall-out traps are rectangular plastic basins filled with soapy water and attached on each corner to vertical poles installed along the edge of the tidal channel (Simenstad et al. 2001). These traps measure the direct input of invertebrates from the marsh to the aquatic system by capturing insects that fall or settle onto the surface of the water (Gray et al 2002). Three replicate traps will be deployed monthly between March and August at each intensive fish sampling site during the low tide and allowed to float with the tide. The traps will be left to sample for 48 hours over an entire tidal cycle before being collected, sieved and preserved. Samples will be identified by qualified personnel or an invertebrate laboratory. Abundance from fall-out trap samples will be standardized to area and reported as average density of invertebrates per m<sup>2</sup>.

Neuston net tows will be used to quantify the availability of pelagic prey organisms within the water column for fish predators (Appendix 13.11). The samples will be collected using a neuston net along the surface of the water column within the slough or channel. Each month, three samples will be collected throughout an outgoing tide at each fish sampling



location and pool contents for 1 sample per site. Samples will be sieved, preserved, and sent to qualified personnel or an invertebrate laboratory for identification, enumeration, and biomass. Abundances from samples will be standardized to area and reported as average density of invertebrates per volume of water.

## 8.5.2 Birds

Port Susan Bay is home to a diverse array of bird species. Waterbirds feed on a variety of resources produced in a healthy estuary including benthic and terrestrial invertebrates, seeds of marsh vegetation, and the stems, leaves and seeds of aquatic vegetation. As such, birds are useful monitoring indicators of the success of the estuary restoration project.

### 8.5.2.1 Area Surveys

Waterbird avian composition, density, and behavior can vary by inundation regime, tide and by season. Area counts that include a high and low tide survey will be conducted monthly using binoculars and spotting scopes near monitoring stations (Appendix 13.12). Surveys should begin before restoration actions begin and continue every month thereafter. Inherent in the monitoring data are spatial and temporal variability associated with the detection of bird anomalies; however only with long term datasets will trends be able to be detected.

Surveys should be conducted during high and low tides at both the restoration site and the reference marsh. High tide surveys are designed to capture the presence of waterfowl and dabbling ducks, and low tide surveys target shorebirds. Near each monitoring station, the site will be partitioned into 125-250 m UTM grids overlaid on a site map with ArcGIS so that an observer can reference the location in which birds are detected (Figure 7). Observers will record grid #, bird species, number of each species, behavior (i.e., foraging, roosting, calling, flyover, swimming), and habitat (i.e., mud flat, marsh plain, open water, aerial, upland or levee) to gauge how birds are using particular habitat types.

Quarterly, area surveys will be conducted on an estuary-wide scale to capture bird use. Estuary-wide surveys will use a 500-m-UTM grid overlaid on the site map, though within the restoration and reference sites, the grid system will not be changed so that data is better comparable to monthly surveys. These surveys may be coordinated with bird surveys of nearby

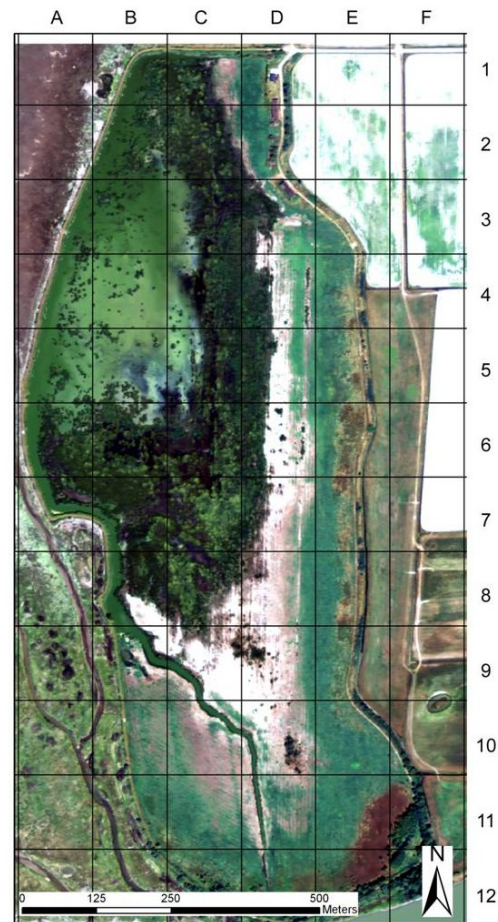

Figure 7. Sample 125m grid overlaid on the restoration site.

agricultural fields as part of TNC's Farming for Wildlife program.

### *8.5.2.2 Variable Circular Plot Surveys*

Variable circular plot surveys should be conducted monthly in the spring between April and June to encompass the breeding season for song birds and the pre-breeding season for marsh birds (Appendix 13.13). Surveys should begin 30 minutes before sunrise and be completed within 2 hours of sunrise (Conway 2009). Once the observer has reached the location for the survey, a two-minute settling period should be followed by eight minutes of data collection when all birds seen and heard within a 150 m radius are recorded. Survey stations are set at least 400 meters apart to reduce spatial autocorrelation (Conway 2009).

### *8.5.2.3 Aerial Flight Surveys*

Aerial flight surveys have been conducted by the Washington Department of Fish and Wildlife. These surveys are conducted annually during the fall-winter migratory season throughout Port Susan Bay. We recommend coordination with the surveys so that bird numbers can be related to GPS locations within the bay and that counts be input onto a 500m grid overlaid on an image of Port Susan Bay. We also recommend that the surveys extend into the agricultural areas where birds are found as part of TNC's Farming for Wildlife program.

### *8.5.2.4 Citizen Scientists*

Nearby routes of North American Breeding Bird Surveys and Christmas Bird Counts will be assessed. These datasets are sampled yearly and can provide vital long-term information regarding species population trends information at a landscape scale.

## **8.5.3 Fish**

Fish are often the primary driver for estuarine restoration because they are signatures of the health and productivity of estuarine systems. In Puget Sound, several species of estuarine-dependant fish are federally listed under the Endangered Species Act, which increases attention and funding for estuary restoration. Fish are ecologically and culturally important to the recovery of Puget Sound and the cultural heritage of its native peoples. Thus, this monitoring plan will focus on the habitat access and capacity it provides for wildlife and fish. Fish sampling within Port Susan Bay has been conducted since 2004 by the Stillaguamish Tribe using beach seines, smolt traps, scope sampling, and fyke nets (ST NRD 2009). Beach seines can be used in a wide variety of shallow water habitats for sampling large schools of adult and juvenile fish. Fyke netting is a passive capture method used for sampling fish in estuary tidal channels (Johnson et al 2007). Monitoring fish response to restoration action should be coordinated with the methods of the Stillaguamish Tribe. Standard operating procedures for salmonid monitoring can be found in the *Salmonid Field Protocols Handbook: techniques for assessing status and trends in salmon and trout populations*, published by the American Fisheries Society in association with the State of the Salmon (Johnson et al 2007).

## 8.6 Data

### 8.6.1 Data Analyses

#### 8.6.1.1 Before-After-Control-Impact Framework

The BACI concept is to examine the Before (pre-construction baseline) and After (post-construction) condition of the area, as well as to compare a Control (reference site) with the Impact site (restoration site). Before and After sampling will determine how the restoration process changed the site through time from its historic condition. Control and Impact sampling will allow effects of restoration actions to be discerned from natural variability, stochastic events, and underlying environmental or species trends in the larger area – for example, sea level rise will increase water levels in the intertidal and adjacent areas within Port Susan Bay. A Control site which has identical environmental conditions to the Impact site is not typically available. Thus, we use the term Reference site (see Smith et al. 1993) to describe areas near the restoration but not part of the area directly affected by the restoration project. The restoration and reference sites are monitored with same methods, intensity, and frequency to allow for paired comparison of the trajectories of the restored and reference site. However, the lack of replicates for the restoration and reference site can be problematic because differences in trajectories may be due to natural site variation and erroneously attributed as a restoration impact. Conquest (2000) argues that the only way to address this variation is to incorporate replicate control and impact trajectories; however, for most restoration sites this is not possible. In these cases Conquest (2000) recommends to “(1) stare hard at good graphs of the data, (2) use process knowledge in one's argument and (3) avoid having to use a p-value.” Regardless, the BACI approach represents a method to analyze the impact of restoration and final interpretation of results should be interpreted with caution and professional expertise

#### 8.6.1.2 Assessing Scaled Objectives

The first two objectives and associated hypotheses (H1.1, H1.2, H1.3, H1.4, H1.5, H1.6, H2.1, H2.2) of the monitoring plan are evaluated at the scale of the restoration site. The third objective and associated hypotheses (H3.1, H3.2, H3.3, H3.4, H3.5) are addressed at the estuary scale. The sampling approach and analysis will be similar for these scales in many regards but will differ by spatial and temporal extent, and by the structure of the data. For example, H1.2 addresses site-specific rates of sediment accretion. To test this hypothesis, we will measure elevation and water levels using methods deployed within the footprint of the restoration site compared to those at the reference site. In contrast, to test a similar hypothesis at the estuary scale (H3.1), the same methods will be used to measure elevation and water levels, with the comparison occurring across time as well as across the spatial scale of the estuary.

#### 8.6.1.3 Change Detection

At the most fundamental level, monitoring using consistent methods will yield information that can be summarized by status and trends or changes over time or rates of change.

Change detection, although simple, can be rather complicated by the fact that detection may change over time, data may vary by observer bias, and natural variability exists within

the ecosystem. The ability to differentiate a change due to the restoration rather than data variability is another complicating factor that can be addressed through a scientific framework of repeated analyses, long term datasets for spatial and temporal trends, and monitoring within a statistical framework.

### *8.6.1.4 Sample Sizes and Data Analyses*

In some cases, it is helpful to assess the sample size needed to detect a certain amount of change (See Heatwole 2006). To statistically test a particular hypothesis in detail, a power analysis will be used to estimate the best sample size. However, most restoration monitoring is determined by practical limits of cost and labor (Table 2). Thus, we have included monitoring sample numbers that reflect our experience with other projects and will provide a good understanding of restoration change.

The focus of most data analyses for monitoring restoration changes are those that provide trends through time. Determining differences may follow frequentist statistics of comparing the number of birds before and after restoration. However, the amount of change that occurs during early restoration is accelerated, so we recommended a 5-10 year period of more intensive monitoring that allows for adaptive management. After the early restoration period, the restoration trajectory is established to a greater extent and a less frequent monitoring schedule of 3-5 years is appropriate.

## **8.6.2 Data Management**

Data handling and storage will follow FGDC (Federal Geographic Data Committee) metadata standards (FGDC 2011). All data should be compiled, QA/QC checked, and archived on a data server with mirrored drives, tape backup, and redundant copies at backup location. Field data will be referenced in GIS coverages, data projected in UTM in NAD83 horizontal and NAVD88 vertical datum. Datasets will be stored by TNC, and monitoring reports will be made available at the TNC website.

Hard copies of field books and data sheets should be made upon return from the field. Data should be entered immediately and entered data should be checked by a different individual. Raw data from data loggers and field surveys should be backed up onto DVDs monthly. Post-processed data should be stored in readily accessible formats such as excel files, jpegs, and shape files, and should be backed up onto DVDs monthly. In addition, if a system network is available, data should be backed up onto the network to ensure its safety.

## **9 INFORMATION SHARING AND COMMUNITY OUTREACH**

### **9.1 Learning and Sharing**

Despite millions of dollars spent on estuary restoration throughout the Pacific Northwest, estuary-dependent species continue to decline and evidence of improvements in estuary function and ecosystem services remains elusive. There are many unanswered questions

with regards to restoration practice that need to be answered in order to achieve better and broader outcomes from our actions, increase the rate and scale of restoration and justify to policy decision makers that continued investment is worthwhile.

Faced continually with the challenges of needing to accomplish more with limited resources, the need for strategic learning and broad sharing of knowledge, tools and experience is growing in importance. TNC has the international and regional connections, and scientific reputation to ensure that monitoring is targeted at issues that will change the practice of restoration broadly, and that knowledge is both exported and imported to maximize the efficiency of learning.

The recently held, collaboratively sponsored, Puget Sound large river delta workshop was a key example of the practice of improving regional learning through collaboration. Local and regional experts input their knowledge in the field of estuary restoration which will guide restoration efforts in Port Susan Bay. Future workshops will assist the continuation of this process.

### 9.2 Lessons Learned

A critical piece to restorations is the learning process at the project scale as well as information sharing at regional scales. Restoration targets and goals are often framed by a particular amount of habitat type restored. However, restoration is not a static state, rather a suite of dynamic processes that can lead to shifting mosaics of wetland habitat types and shifting importance for different types of wildlife. Restoration trajectories should be allowed to encompass multiple possibilities due to changing environmental conditions and uncertainties and be refined with additional learning.

At the practical level, integrating monitoring with construction or other ongoing monitoring activities by others can improve efficiencies and strengthen partnerships. The following are some of the core lessons learned recommendations from a project management perspective.

- Obtain as-built surveys producing a map of the final elevations
- Use consistent datum for construction and monitoring
- Install elevation benchmarks and consider locations that will benefit construction and long term monitoring
- Create and maintain clear metadata for all data files
- Keep databases organized, updated, and backed up
- Obtain raw data files and metadata for the studies conducted on site
- Obtain at least 1yr of pre-restoration baseline
- Incorporate at least 1 reference marsh (if possible) into the monitoring plan
- Detailed notes on management decisions and actions, and resulting outcomes
- Aerial bird surveys to be extended into adjacent agricultural lands in Port Susan Bay
- Include spatial GPS data with aerial bird data, or partition by subareas within Port Susan Bay



### 9.3 Potential Monitoring Partners

A coordinated working group of regional agencies and partners will assist the effectiveness of monitoring and facilitate regional learning. A collaborative program based on consistent methodologies and metrics will reduce effort, increase scalability and seamless sharing of data across the region, increase sample size, increase achievability of results (Crawford et al. 2010). Additional opportunities exist to create partnerships with local universities, colleges, agencies, and citizen groups.

### 9.4 Citizen Science

“Involving unpaid volunteers has the advantages of being economic, can extend the geographic range of study sites and the frequency of visits, and can have huge educational advantages for all levels of society” (Bonney et al. 2009). Citizen science is an increasingly utilized, cost efficient, resource to assist the monitoring of biological and physical processes (e.g. Christmas Bird Count, World Monitoring Day). Interested volunteers and bird enthusiasts can be recruited to assist with bird counts or native species planting days. Citizen science activities are important linkages between a community and the conservation of natural resources and are important tools to engage and educate the local community and public about local restoration efforts. Citizen scientist and bird enthusiasts can be vital to long term monitoring programs. Volunteers can assist with bird monitoring within the restoration site.

A public website should be developed to provide updates of the restoration to the community, stakeholders, funders, and interested parties (e.g. <http://nisquallydeltarestoration.org>). Field updates should also be posted to document restoration progress through pictures, video, and real time data.

### 9.5 Web Portal

A major goal of the restoration program is to provide public and scientific outreach on the progress of restoration efforts. Monitoring updates, status, and trend results will be made available for the public online with a website (see example at: <http://www.nisquallydeltarestoration.org>). These data will be useful to support environmental education, for coordination among researchers, and for managers. It will provide information and lessons learned to the broader restoration community in Puget Sound. Data summaries and presentations about preliminary findings will be available for local land management agencies and other interested parties. To foster environmental stewardship, interested members of the public will be able to track the progress of the study, view images, and download reports to stay connected with up to date restoration progress.

## 10 TIMELINE

The Port Susan Bay monitoring plan covers over 30 years to allow for short and long-term measurements of restoration success, adaptive management, and better understanding of climate change impacts to both the restoration site and Stillaguamish estuary. The timeline



is broken into 3 periods: pre-restoration baseline monitoring (2003 – 2012), varied levels of intensive monitoring 5 years post-dike removal (2012 – 2017), and 25 years of periodic monitoring conducted at 3-5 year intervals (2022 – 2042). Preliminary results will be used, if needed, to adjust monitoring priorities, effort, and frequency in order to best answer restoration questions. Continued monitoring beyond 2042 will be dependent upon results from the 30 years of data collected (Table 3). In addition, the scale and intensity of monitoring will always be dependent on funding, and, while we make no specific monitoring commitments in the absence of funding, this document will guide the application of any funding obtained.

## 11 ACKNOWLEDGMENTS

Any use of trade, product, or firm names in this publication is for descriptive purposes only and does not imply endorsement by the U.S. government.

Development of this monitoring plan was supported by The Nature Conservancy and the USGS Western Ecological Research Center. We would like to thank Paul Cereghino with the NOAA Restoration Center and Puget Sound Nearshore Ecosystem Restoration Project for ideas, and participants of the Large River Delta Workshop for providing ideas that have benefited the plan. We would like to thank the Washington Department of Fish and Wildlife (Betsy Lyons), and we acknowledge and thank Kat Morgan, Julie Morse, Joeline Diehl, and Danelle Heatwole (TNC) for valuable input and baseline data collection. We thank TNC's Estuary Science Advisory Panel: Jennifer Ruesink, John Rybzyk, Craig Cornu, Charles Simenstad, Mary Ruckleshaus, Rob Butler, Mary Kentula, Michelle Marvier. We also would like to thank Erin Flynn, Laura Shaskey, and Ashley Smith of the USGS Western Ecological Research Center for cartographic assistance and manuscript review.

Table 3. Port Susan Bay annual monitoring priorities and timeline. Survey and maintenance frequencies are color-coded (annual = blue, semiannual = green, quarterly = yellow, monthly, seasonal = orange, monthly = pink). Baseline data (gray) were collected using different scale, methods and frequency than listed.

Monitoring Group (Category)	Method	Pre-Restoration					Post-Restoration									
		Baseline & Construction					Intensive <sup>1</sup>					Periodic <sup>2</sup>				
		2003	2004	2005	2011	2012	2013	2014	2015	2016	2017	2022	2027	2032	2037	2042
<b><u>Elevation</u></b>																
Remote Sensing	LiDAR			Gray	Blue		Blue			Blue		Blue			Blue	
Ground-based	RTK GPS				Blue		Blue		Blue		Blue			Blue		
Bathymetry	Echosounder				Blue		Blue		Blue		Blue			Blue		
<b><u>Habitat</u></b>																
Sub-area	photo-points				Blue		Blue		Blue		Blue			Blue		
Area	aerial photographs	Gray			Blue		Green		Blue		Blue			Blue		
Communities	aerial photographs				Blue		Green		Blue		Blue			Blue		
Vegetation	transect with quadrats, plot		Gray		Blue		Blue		Blue		Blue			Blue		
Large Woody Debris	aerial photographs		Gray		Blue		Green		Blue		Blue			Blue		
Channels	Cross-sections		Gray		Blue		Blue		Blue		Blue			Blue		
<b><u>Hydrology</u></b>																
Continuous Water Level, Temperature, Conductivity	continuous loggers			Gray	Yellow		Yellow		Yellow		Yellow			Yellow		
Continuous Water Quality	continuous loggers				Yellow		Yellow		Yellow		Yellow			Yellow		
Discrete Water Quality	spot metering				Yellow		White		Yellow		Yellow			Yellow		
Nutrients & Hydrodynamics	grab samples ADCP				Yellow		Yellow		Yellow		Yellow			Yellow		
<b><u>Sedimentation</u></b>																
Accumulation	sediment pins				Green		Green		Green		Green			Green		
Sediment Elevation	SETs, marker horizons				Green		Green		Green		Green			Green		
Soil Characteristics	with cores				Green		Green		Green		Green			Green		
<b><u>Fauna</u></b>																
Terrestrial Invertebrates	Fall out traps				Orange		Orange		Orange		Orange			Orange		
Pelagic Invertebrates	neuston tows				Orange		Orange		Orange		Orange			Orange		
Benthic Invertebrates	cores				Orange		Orange		Orange		Orange			Orange		
Birds	area survey	Gray			Pink		Pink		Pink		Pink			Pink		
Birds	circular plots				Orange		Orange		Orange		Orange			Orange		
Fish	Fyke net				Orange		Orange		Orange		Orange			Orange		
Fish	Beach seine				Orange		Orange		Orange		Orange			Orange		

<sup>1</sup> Intensive surveys will be conducted annually for the first five years.

<sup>2</sup> Periodic surveys will be conducted every 3-5 years.

## 12 REFERENCES

- Athearn, N., Takekawa, J.Y., Jaffe, B., Hattenbach, B.J., and A.C. Foxgrover. 2010. Mapping elevations of tidal wetland restoration sites in San Francisco Bay: comparing accuracy of aerial LiDAR with a singlebeam echosounder. *Journal of Coastal Research* 26(2): 312-319.
- Bennett, E.M. 2005. A systems model approach to determining resilience surrogates for case studies. *Ecosystems* 8: 945-957.
- Bonney, R., Cooper, C.B., Dickinson, J., Kelling, S. Phillips, T., Rosenberg, K.V., and J. Shirk 2009. Citizen science: a developing tool for expanding science knowledge and scientific literacy. *BioScience* 59(11): 977-984.
- Boyer, K. E. and J. B. Zedler. 1998. Effects of nitrogen additions on the vertical structure of a constructed cordgrass marsh. *Ecological Applications* 8: 692-705.
- Brown, N.A. and J.K. Gaydos. 2007. Species of concern within the Georgia Basin Puget Sound Marine Ecosystem: changes from 2002 to 2006. *Species of Concern, Proceedings of the 2007 Georgia Basin Puget Sound Research Conference*. March 26-29 2007, Vancouver, B.C.
- Cahoon D.R., and J.C. Lynch. 2003. USGS Patuxent Wildlife Research Center Surface Elevation Table website. Online Resource. <http://www.pwrc.usgs.gov/set>. (accessed 15 Feburary 2011).
- Callaway, J. C., G. Sullivan, J. S. Desmond, G. D. Williams, and J.B. Zedler. 2001. Assessment and monitoring. Pp 271-335 *In* J. B. Zedler, editor. *Handbook for Restoring Tidal Wetlands*. CRC Press. Boca Raton, Florida.
- Clough, J.S., and E.C. Larson 2010. Application of SLAMM 6 to Port Susan Bay including remedial alternatives. January 15, 2010. TNC Internal Document.
- Collins, B. 1997. Effects of land use on the Stillaguamish River, Washington, ~1870 to ~1990: Implications for salmonid habitat and water quality and their restoration. Unpublished report to the Stillaguamish Tribe of Indians Natural Resources Department, Arlington, WA.
- Collins, B. 2000. Mid -19<sup>th</sup> century stream channels and wetlands interpreted from archival sources of three north Puget Sound estuaries. Unpublished report to the Skagit River System Cooperative, La Conner, WA; Bullitt Foundation, Seattle, WA; and Skagit Watershed Council, Mt. Vernon , WA.
- Conquest, L. L. 2000. Analysis and Interpretation of Ecological Field Data Using BACI Designs: Discussion. *Journal of Agricultural, Biological, and Environmental Statistics* 5(3): 293-296.
- Conway, C. J. 2009. Standardized North American Marsh Bird Monitoring Protocols, version 2009-2. Wildlife Research Report #2009-02. U.S. Geological Survey, Arizona Cooperative Fish and Wildlife Research Unit, Tucson, AZ.
- Craft, C. 2000. Co-development of wetland soils and benthic invertebrate communities following salt marsh creation. *Wetlands Ecology and Management* 8: 197-207.
- Crawford, B., O'Neal, J., Newsom, M., and J. Geiselman. 2010. Coordinated habitat action effectiveness monitoring. Pacific Northwest Aquatic Monitoring Partnership and Washington Forum on Monitoring Work Session #3. August 10, 2010.

- Cullinan, T. 2001. Important bird areas of Washington. Audubon Washington, Olympia, Washington. 170pp.
- Dunwiddie, P.W., Hall, S.A., Ingraham, M.W., Bakker, J.D., Nelson, K.S., Fuller, R. and E. Gray. 2009. Rethinking conservation practice in light of climate change. *Ecological Restoration* 27: 320-329.
- Ellings, C.S., and S. Hodgson. 2007. Nisqually river estuary baseline fish ecology study: 2003-2006. Unpublished report of Nisqually National Wildlife Refuge and Nisqually Indian Tribe, Olympia, Washington.
- Ewing, K. 1986. Plant growth and productivity along complex gradients in a Pacific Northwest Brackish Intertidal Marsh. *Estuaries* 9: 49-62.
- Federal Geographic Data Committee. 2011. Geospatial Metadata. Online Resource. <http://www.fgdc.gov/metadata>. (accessed 24 February 2011).
- Friedrichs, C.T., and J.E. Perry. 2001. Tidal salt marsh morphodynamics: a synthesis. *Journal of Coastal Research* SI 27:7-37.
- Fuller, R. 2004. The greater Skagit Delta biodiversity assessment and conservation plan. Unpublished report to The Nature Conservancy. 63pp.
- Glick, P., Clough, J., and B. Nunley. 2007. Sea level rise and coastal habitats in the Pacific Northwest. Unpublished report to National Wildlife Federation. 106pp.
- Gray, A., C.A. Simenstad, D.L. Bottom, and T.J. Cornwell. 2002. Contrasting functional performance of juvenile salmon habitat in recovering wetlands of the Salmon River Estuary, Oregon, U.S.A. *Restoration Ecology* 10:514-526.
- Griffith, J. 2005. Mapping nearshore and delta habitat in Port Susan. Unpublished report Stillaguamish Tribe Natural Resources Department to FY 2003 BIA Watershed Restoration Funds Final Report.
- Heatwole, D. 2006. Habitat mapping and characterization in Port Susan Bay: Summary of 2004 and 2005 monitoring. Unpublished report of The Nature Conservancy, Seattle. 19pp.
- Hood, W.G. 2004. Indirect environmental effects of dikes on estuarine tidal channels: thinking outside of the dike for habitat restoration and monitoring. *Estuaries* 27:273-282.
- Hood, W. G. 2006. A conceptual model of depositional, rather erosional, tidal channel development in the rapidly prograding Skagit River Delta (Washington, USA). *Earth Surface Processes and Landforms*. Online only.
- Hood, W. G. 2007. Scaling tidal channel geometry with marsh island area: a tool for habitat restoration, linked to channel formation process. *Water Resources Research* 43: W03409.
- Hood, W.G. 2009. Habitat monitoring strategy for the tidal Skagit delta: integrating landscape and site-scale perspectives. Unpublished report to Skagit River System Cooperative. 44pp.
- IPCC, 2007: Summary for Policymakers. *In: Climate Change 2007: The Physical Science Basis. Contribution Working Group I to the Fourth Assessment Report of the Intergovernmental Panel on Climate Change* [Solomon, S., D. Qin, M. Manning, Z. Chen, M. Marquis, K.B. Averyt, M. Tignor and H.L. Miller, editors.]. Cambridge University Press, Cambridge, United Kingdom and New York, NY, USA.

- Janisch, J. 2006. Standard operating procedures for estimating large woody debris loads intersecting headwater channels. V. 1.0. Unpublished report of the Washington State Department of Ecology, Environmental Assessment Program. Lacey, WA.
- Jevrejeva, S., Moore J.C., Grinsted, A. and P.L. Woodworth. 2008. Recent global sea level acceleration started over 200 years ago? *Geophysical Research Letters* 35: L08715.
- Jevrejeva, S., A. Grinsted, J. C. Moore and S. Holgate. 2006. Nonlinear trends and multi-year cycle in sea level records. *Journal of Geophysical Research* 111: JC003229.
- Johnson, D. H., B. M. Shrier, J. S. O'Neal, J. A. Knutzen, X. Augerot, T. A. O'Neil, and T. Pearsons, editors. 2007. *Salmonid field protocols handbook: techniques for assessing status and trends in salmon and trout populations*. American Fisheries Society in association with State of the Salmon, Bethesda, Maryland. 478 pp
- Johnson, G.E. (editor.). 2007. Evaluating cumulative ecosystem response to restoration projects in the Columbia River estuary, Annual Report 2006. PNNL-16561. Report to the U.S. Army Corps of Engineers, Portland District, by Pacific Northwest National Laboratory, Richland, Washington.
- Lee, K. 1993. *Compass and Gyroscope: integrating science and politics for the environment*. Washington, D.C: Island Press, 255pp.
- Kennish, M.J. (editor). 2003. *Estuarine Research, Monitoring, and Resource Protection*. Boca Raton, Florida: CRC Press, 297p.
- Kennish, M.J., and A.R. Townsend. 2007. Nutrient enrichment and estuarine eutrophication. *Ecological Applications* 17(5): S1-S2.
- Lind-Null, A., Larsen, K., and R. Reisenbichler. 2008a. Pre-Restoration habitat use by Chinook Salmon in the Nisqually Estuary using otolith analysis: U.S. Geological Survey Open File Report 2008-1021, 13 pp.
- Lind-Null, A., Larsen, K., and R. Reisenbichler. 2008b. Characterization of estuary use by Nisqually Hatchery Chinook based on otolith analysis: U.S. Geological Survey Open File Report 2008-1102, 12 pp.
- Lind-Null, A., and K. Larsen. 2009. Pre-Restoration habitat use by Chinook Salmon in the Nisqually Estuary using otolith analysis: An additional year: U.S. Geological Survey Open File Report 2009-1106, 18 pp.
- Lombard, J. and K. Johnson. 2010. *Envision Skagit 2060 Citizen Committee Orientation Packet*. Available online at <http://www.skagitcounty.net/EnvisionSkagit/Documents/Orientation%20Report%20Citizen%20Committee.pdf> (accessed 3 February 2010).
- National Estuarine Research Reserve System (NERRS). 2002. NERR SWMP nutrient sampling protocol. Technical Document, National Estuarine Research Reserve System, National Oceanic and Atmospheric Administration, Silver Spring, Maryland.
- National Estuarine Research Reserve System (NERRS). 2004. Nutrient and chlorophyll monitoring program and database design. Technical Report, NOAA/NERRS Nutrient Monitoring Committee, National Oceanic and Atmospheric Administration, Silver Spring, Maryland.
- NCRT (Nisqually Chinook Recovery Team). 2001. *Nisqually Chinook Recovery Plan*. Unpublished Report 15pp.
- Neckles, H.A., Dionne, M., Burdick, D.M., Roman, C.T., Buchsbaum, R., and E. Hutchins. 2002. A monitoring protocol to assess tidal restoration of salt marshes on local and regional scales. *Restoration Ecology* 10(3):556-563.

- Odum, E.P 1969. The strategy of ecosystem development. *Science* 164:262-270.
- Omerod, S.J. 2003. Restoration in applied ecology: editor's introduction. *Journal of Applied Ecology* 40(2):44-50.
- Park, R.A., Trehan M.S., Mausel P.W., and Howe R.C. 1989. The effects of sea level rise on US coastal wetlands. *In* Smith, J.B. and Tirpak, D.A., editors. The potential effects of global climate change on the United States. Appendix B – sea-level rise. Washington, DC: US Environmental Protection Agency.
- Parker, V.T. and S.T.A Pickett. 1997. Restoration as an ecosystem process: implications of the modern ecological paradigm. Pp17-23 *In*: Urbanska, K.M., Webb, N.R., Edwards, P.J., editors. Restoration ecology and sustainable development. Cambridge (UK): Cambridge University Press.
- Pickett S.T.A. and Parker, V.T. 1994. Avoiding the old pitfalls: opportunities in a new discipline. *Restoration Ecology* 2:75-79.
- Roman, C.T., Raposa, K.B., Adamowicz, S.C., James-Pirri, M., and J.G. Catena. 2002. Quantifying vegetation and nekton responses to tidal restoration of a New England salt marsh. *Restoration Ecology* 10(3): 450-460.
- Roman, C.T., Niering, W.A., and R.S. Warren. 1984. Salt marsh vegetation change in response to tidal restriction. *Environmental Management* 8(2): 141-150.
- Shared Strategy for Puget Sound. 2011. [www.sharedsalmonstrategy.org](http://www.sharedsalmonstrategy.org). Accessed 1/27/2011.
- Simenstad, C.A., A.J. Wick, J.R. Cordell, R.M. Thom, and G.D. Williams. 2001. Decadal development of a created slough in the Chehalis River estuary: year 2000 results. Report to U.S. Army Corps of Engineers, Seattle District.
- Slater, G.L. 2004. Waterbird abundance and habitat use in estuarine and agricultural habitats on the Skagit and Stillaguamish River Deltas. Final Report to The Nature Conservancy, Seattle, WA
- Slater, G.L. and J. D. Lloyd 2010. Farming for Wildlife: effects of flooding forage harvest, and grazing on shorebirds, soil invertebrates, and vegetation on agricultural fields in the Skagit River Delta, WA. Final Report to The Nature Conservancy, Mount Vernon, WA
- Smith, P.E., Orvos, D.R., and J. Cairns. 1993. Impact assessment using the before-after-control-impact (BACI) model: concerns and comments. *Canadian Journal of Fisheries and Aquatic Sciences* 50:627-637.
- Snohomish County. 1995. Snohomish County GMA Comprehensive Plan: Future Land Use – GIS Data. Everett, WA.
- Snohomish County. 2010. Demographics, Snohomish County, Online Government Information & Services. Available online at [http://www1.co.snohomish.wa.us/Departments/PDS/Divisions/PlanningandTechnology/LR\\_Planning/Information/Demographics/DemographicsFAQs.htm](http://www1.co.snohomish.wa.us/Departments/PDS/Divisions/PlanningandTechnology/LR_Planning/Information/Demographics/DemographicsFAQs.htm) (accessed 3 February 2010).
- Snohomish County. 2010. Shoreline Modifications Map, Surface Water Management Division, Snohomish County, Online Government Information & Services. Available online at [http://www.co.snohomish.wa.us/documents/Departments/Public\\_Works/surfacewatermanagement/Maps/shor\\_mod.pdf](http://www.co.snohomish.wa.us/documents/Departments/Public_Works/surfacewatermanagement/Maps/shor_mod.pdf) (accessed 3 February 2010).



- Stillaguamish Tribe, Natural Resource Department. 2009. Stillaguamish Estuary use by juvenile Chinook, final report. Unpublished report for FY 2005 Pacific Coastal Salmon Recovery Funding. 23pp.
- Society for Ecological Restoration International Science & Policy Working Group (SERI SPWP) 2004. The SER International Primer on Ecological Restoration. Society for Ecological Restoration International. Online Resource.  
[http://www.ser.org/content/ecological\\_restoration\\_primer.asp#5](http://www.ser.org/content/ecological_restoration_primer.asp#5) (accessed 24 February 2011).
- Stewart-Oaten, A. 1996. Goals in environmental monitoring. Pp. 17-27 *In* RJ Schmitt and CW Osenber, editors. Detecting Ecological Impacts: Concepts and applications in coastal habitats. Academic Press, San Diego, CA.
- Stewart-Oaten, A., W. W. Murdoch, and K. R. Parker. 1986. Environmental impact assessment: "pseudoreplication" in time? *Ecology* 67:929-940.
- Stewart-Oaten, A., J. R. Bence, and C. W. Osenberg. 1992. Assessing effects of unreplicated perturbations: no simple solutions. *Ecology* 73:1396-1404.
- Stewart-Oaten, A. 2003. On rejection rates of paired intervention analysis: comment. *Ecology* 84:2795-2799.
- Stillaguamish River Basin Characteristics (SRBC). 2003. Pp 2-1 -2-11 *In* Stillaguamish River Comprehensive Flood Hazard Management Plan. 2003. Unpublished report of the Snohomish County Public Works: Surface Water Management
- Stillaguamish Implementation Review Committee (SIRC). 2005. Stillaguamish Watershed Chinook Salmon Recovery Plan. Published by Snohomish County Department of Public Works, Surface Water Management Division. Everett, WA.
- Stillaguamish Tribe, Natural Resource Department (ST NRD). 2009. Stillaguamish Estuary Use by Juvenile Chinook. Final Unpublished report to Pacific Coastal Salmon Recovery Funding. 23pp.
- Thom, R.M., A.B. Borde, N.R. Evans, C.W. May, G.E. Johnson, and J.A. Ward. 2004. A Conceptual Model for the Lower Columbia River Estuary Prepared by Pacific Northwest National Laboratory for the U.S. Army Corps of Engineers, Portland District
- Underwood, A. J. 1992. Beyond BACI: the detection of environmental impacts on populations in the real, but variable, world. *J. Exp. Mar. Biol. Ecol.* 161:145-178.
- U.S. Census Bureau. 2010. State and County Quick Facts. Data derived from Population Estimates, Census of Population and Housing, Small Area Income and Poverty Estimates, State and County Housing Unit Estimates, County Business Patterns, Nonemployer Statistics, Economic Census, Survey of Business Owners, Building Permits, Consolidated Federal Funds Report. Available online at <http://quickfacts.census.gov/qfd/states/53/53057.html> (accessed 3 February 2010).
- U.S. Environmental Protection Agency (EPA). 2006. Puget Sound Basin transboundary ecosystem indicator report. Unpublished report to Environmental Protection Agency (EPA). 203pp
- Vermeer, M., Rahmstorf, S. 2009. Global sea level linked to global temperature. *Proc. Nat. Acad. Sci.* 106:21527-21532.
- Washington Department of Natural Resources (WA DNR). 2009. State Board on Geographic Names approves 'Salish Sea'. Online Resource.  
[http://www.dnr.wa.gov/ResearchScience/News/Pages/nr09\\_177.aspx](http://www.dnr.wa.gov/ResearchScience/News/Pages/nr09_177.aspx) (accessed 24 February 2011)

- Wissmar, R.C., and P.A. Bisson, editors. 2003. Strategies for restoring river ecosystems: sources of variability and uncertainty in natural and managed systems. Bethesda ,MD: American Fisheries Society.
- Woo, I., J. Y. Takekawa, A. Rowan, R. Gardiner, O. Bernstein, and G. T. Block. 2007. The Tubbs Setback Restoration Project: Final Report. U. S. Geological Survey. Unpublished Final Report. Vallejo, CA.
- Woo, I., and J. Y. Takekawa. 2008. Restoration of the Nisqually estuary: monitoring initial progress of the Nisqually National Wildlife Refuge tidal restoration. USGS proposal to the FWS Nisqually National Wildlife Refuges. Vallejo, California. 11pp.
- Woo, I., R. Storesund, J.Y. Takekawa, R.J. Gardiner, and S. Ehret. 2009. Integrating Terrestrial LiDAR and Stereo Photogrammetry to Map the Tolay Lakebed in Northern San Francisco Bay. Pp 279-284 *In* Webb, R.M.T., and Semmens, D.J., editors. Planning for an uncertain future—Monitoring, integration, and adaptation. Proceedings of the Third Interagency Conference on Research in the Watersheds: U.S. Geological Survey Scientific Investigations Report 2009-5049.
- Yang, A., Sobocinski, K.L., Heatwole, D., Khangaonkar, T., Thom, R., and R. Fuller. 2010. Hydrodynamic and ecological assessment of nearshore restoration: A modeling study. *Ecological Modeling* 221: 1043-1053.
- Zedler, J. B. 2000. Handbook for Restoring Tidal Wetlands. CRC Press. Boca Raton, FL. 439pp.
- Zedler, J. B., and J.C. Callaway. 2003. Adaptive restoration: A strategic approach for integrating research into restoration projects. Pp. 167-174 *in* D. J. Rapport, W. L. Lasley, D. E. Rolston, N. O. Nielsen, C. O. Qualset, and A. B. Damania, eds. *Managing for Healthy Ecosystems*. Lewis Publishers, Boca Raton, Florida.
- Zedler, J.B. 2005. Ecological restoration: guidance from theory. *San Francisco Estuary and Watershed Science* 3(2):1-31.

### 13 APPENDICES

Appendices include standard operating procedures (SOPs) for each method presented in the monitoring plan, excluding those tasks that will be contracted out due to requirements for specialized equipment and training (i.e. LiDAR, aerial photography, bathymetric mapping, ADCP, etc.). These methods are adapted from published methods, or developed by in-house technical and administrative experts. Their primary purpose is for internal use, although sampling and administrative SOPs may have wider utility. Our SOPs do not replace or supersede official published methods. Distribution of these SOPs does not constitute an endorsement of a particular procedure or method. Any reference to specific equipment, manufacturer, or supplies is for descriptive purposes only and does not constitute an endorsement of a particular product or service. Although the USGS Western Ecological Center, The Nature Conservancy, and the Nisqually Tribe follow the SOP in most instances, there may be instances in which they use an alternative methodology, procedure, or process. These SOPs are not published and represent internal documentation and training for USGS staff.

A list of potential monitoring collaborators is included in Appendix 13.16.

*For questions/comments please contact Isa Woo [iwoo@usgs.gov](mailto:iwoo@usgs.gov), John Takekawa [john\\_takekawa@usgs.gov](mailto:john_takekawa@usgs.gov), or Roger Fuller [rfuller@TNC.org](mailto:rfuller@TNC.org)*

## 13.1 Photo-Point Standard Operating Procedures

USGS Western Ecological Research Station SFBE

Suggested citation: US Geological Survey. 2011. Photo-point standard operating procedures. Unpublished protocols. USGS, Western Ecological Research Center, San Francisco Bay Estuary Field Station, Vallejo, CA.

*Disclaimer: Any use of trade, product, or firm names in this publication is for descriptive purposes only and does not imply endorsement by the U.S. government.*



### **Purpose/Objective:**

Each year, a set of panoramas is taken during mid- to late summer within a month of aerial photographs. Additional photo monitoring should be done before and after significant geomorphological changes caused by natural and human events.

### **Equipment:**

Digital camera (high resolution)  
Tripod if possible  
Compass  
GPS  
Set of previous images

List of photo-point UTM's and compass bearings  
Aerial photo of site with photo-point locations  
Field notebook  
Tide chart

### **Methods:**

1. Photopoints should always be taken at low tide (less than 2 ft.).
2. Locate photo-points in the field using previous year's images, UTM coordinates, and compass bearings.
3. Take a series of images at each photo-point which represent the same location and panoramic as created in the past (use previous photos and recorded compass bearings). If this is the first time photo-points have been taken, take the first photo in the series facing south.
4. Usually three to six photos are taken to capture a 180 degree panorama from a location. Set camera to landscape setting and try to get equal amount of land and sky in the photos so when building the panorama it won't cut off hilltops or important features closer to your feet. If you can get a much better view of the site by being raised a couple feet (i.e. standing on the back of truck bed) then please do this, otherwise just take from the ground.
5. Record the date, site, point number, and number of photos taken for each panoramic during a session in the field, this data is important later when you are merging photos into panoramas.
6. Download images from the camera and place in appropriate location. Photos that make up panoramas should be re-named to reflect their location and date of origin
7. There are different programs to use to create the panoramic. Use the latest version of Adobe if available, otherwise use the Hugin program.

### ***Procedure for making Panoramas with Hugin Program***

1. Open up the panoramic program Hugin.
2. Click on the **Load Images** button and browse to the location of all of the photos taken at one photopoint.
3. Click on align. Press **OK** to all of the error messages.
4. Click on the **Images** tab and delete any photos that are not part of the panoramic (some may have one photo with just the name or location of the photopoint that should be deleted).
5. Then look at the previous year's panoramic photo from the same site and photopoint. Check what the photo looks like on the left and right ends. Use hills and other features to approximate where the left and right edges of the new panoramic should be. Most of the time the photos will already be in the right order.
6. Then click on the **Control Points** tab.
7. Pick items that you can see on both images for control points (e.g., posts, trees, rocks). Click on one photo to zoom in and put the control point in a particular spot.
8. Then click on the same general area of the position in the other photo and it should automatically zoom into the control point on the photo. Click the **Add** button.
9. Try to make three or four control points between each photo.
10. If it cannot find the control point on the other photo, retry with a different control point until you can get one that automatically finds the same point on the other photo.
11. Sometimes it finds the wrong position, so be sure to check that they are at the right position before adding. Another option is to delete the control point after you have added it.
12. Click the right arrow in the top right corner to continue to the next photo and add photo points.
13. When you have installed 3-5 control points for each photo, go back to the **Assistant** tab and click on the align button.
14. It will then produce a preview panoramic.
15. If this looks ok then crop the top and bottom so that no black space is showing. You can also move the panoramic around left to right and straighten the picture.
16. Then exit the preview and click create panoramic.
17. Save the panoramic and create a folder with the panoramic tiff image and hugin project file for each photopoint.

### ***Instructions for Adobe:***

1. Be sure to "save a copy" in Adobe. This step allows for the extension .jpg, which enables photos to be opened in other programs.
2. Name panoramas according to the location and date they were taken.
3. When all panoramas are completed for that site, they can be compiled onto one Microsoft Word document. Open a blank word document and in the top center in bold, title it with the site name and the month/year. From here Insert\Picture\From File and navigate to the .jpg version of each panorama to get each picture onto the document. Title each panoramic with the photo-point number.
4. Make sure to keep all of the data (i.e., date, time, tide, photopoint location, etc.) with the panoramic.
5. Panoramas can later be altered (e.g., canvas size, contrast, etc.) in Adobe Photoshop to be of similar dimensions and quality for placement in a report.
6. Folders should be zipped in order to reduce their size. Zip both the raw photos and the panoramas. This can be done by right clicking on the folder, clicking on power desk, and then clicking on Zip. The destination of the zipped folder can be the same one as the unzipped folders. The zipping process may take a bit of time, but when it is complete you can delete the unzipped photos.

### ***Procedure for Making Panoramas with Adobe Photoshop v.7.0.***

1. Insert memory chip into USB card reader or attach camera directly to USB port on computer.
2. Copy all necessary photos into the proper folders by click-dragging or copying.
3. Open first photo-point photo (farthest on the left 1<sup>st</sup>) with Adobe Photoshop. Multiple photos can also be opened at once.
4. This image will be too large to work with initially; on the menu bar under **Image**, click on **Image Size** and choose 8"x 6" or some other manageable size.
5. Then open a separate (new) canvas, click on canvas size and increase the width to 40" or more. This will allow you room to add all of your images from one photopoint to your canvas.
6. Move the first image all the way to the left of the canvas by using the arrow tool (top right icon in the Adobe tool box).
7. Go back to the photo file you are working with and open the next photo from the left.
8. Reduce the photo to 8" x 6" (**Image>Image Size**)
9. Drag and drop the second photo onto the original enlarged canvas; line up the photos using the arrow keys.
10. If the color, brightness, contrast, etc. needs changing, go to **Image>Adjust** to make the necessary adjustments. You can adjust each photo by clicking on the proper layer in the layer tool box, located in the bottom right corner. You can make fine adjustments to each layer before or after you put together the panoramic.
11. Repeat this process until all the necessary photos are lined up and adjusted to make the panoramic.
12. Then use the crop feature to cut off uneven edges. Use the perforated square to encompass the part of the photo you want. Then go to **Image>Crop** to even off the photo.
13. If the photo is done, you must "flatten" the image in order to save space. Go to **Layer>Flatten Image**. This turns all the images into one photo, therefore you can no longer work with the originals.
14. Now save the panoramic, as a JPEG, in the necessary file. Use Pt.1, Pan.1, or PhotoPt.1 to signify that it is a panoramic of a photo-point.
15. Once you are sure you have all the photos downloaded and you are done working with them, remember to delete the original photos from camera.

### ***Procedure for Making Panoramas with Adobe Photoshop CS2***

1. Insert memory chip into USB card reader or attach camera directly to USB port on computer.
2. Copy all necessary photos into the proper folders by click-dragging or copying.
3. Open first photo-point photo (farthest on the left 1<sup>st</sup>) with Adobe Photoshop.
4. Right click on the header of the photo, select **Canvas Size**. Change the width of the canvas to allow for additional photos to be added: 120 inches is a good start. You can always expand this later. Do not increase the height.
5. Change the anchor location. Choose the left-most grid to allow for images to be added to the right. Select **OK**.
6. Go back to the photo file you are working with and open the next photo from the left. Press **Control-A** to select the image, then **Control-C** to copy the image. Select the canvas with the extended width and press **Control-V** to paste.
7. Right click on the newly pasted image and select **Free Transform**. New image can now be dragged to align with the edge of the first image with your mouse and fine tune adjustments can be made with the keyboard arrows. Press **Enter** when the images are aligned to turn off free transform.



*Note: You can place layers behind other layers by changing their order in the table of contents. This may be necessary to get the best alignment.*

8. Repeat steps 6 and 7 until all images are on the canvas.
9. Adjust for differences between the layers. Select the layer you would like to adjust by clicking on the layer in the table of contents. You can be sure you have the right layer by clicking on the eye symbol. If the color, brightness, contrast, etc. needs changing, go to **Image>Adjust** to make the necessary adjustments.
10. Crop the image. Select the **Rectangular Marquee Tool** from the tool chest and make a rectangle that omits all the white edges around the new panorama. In the menu bar, select **Image**, then **Crop**.
11. Flatten the image. This step compiles all the layers together so individual adjustment are no longer possible. In the menu bar, select **Layer**, and then **Flatten**.
12. Save the panorama as a high quality JPEG while following the naming conventions. Use Pt.1, Pan.1, or PhotoPt.1 to signify that it is a panoramic of a photo-point.
13. Follow conventions on file storage and zip folders for storage on N drive.
14. Once you are sure you have all the photos downloaded and you are done working with them, remember to delete the original photos from camera

## 13.2 RTK GPS Standard Operating Procedures

USGS Western Ecological Research Station SFBE

Suggested citation: US Geological Survey. 2011. RTK GPS standard operating procedures. Unpublished protocols. USGS, Western Ecological Research Center, San Francisco Bay Estuary Field Station, Vallejo, CA.

*Disclaimer: Any use of trade, product, or firm names in this publication is for descriptive purposes only and does not imply endorsement by the U.S. government.*

### Purpose/Objective:

Ground-based topographic mapping using real time kinematic global positioning system (RTK GPS) is a useful tool for collecting high resolution elevation data at the landscape level. RTK GPS is mobile, collects data quickly, and measures elevation within an accuracy of 1 – 5 cm.

### Equipment:

RTK GPS loaded with gridlines  
Site map with gridlines

### Methods:

#### Field

RTK elevation points are taken every 25m along transects stratified from high to low elevations. The technician paces 25m between points and uses the RTK map to establish relatively straight and parallel transect lines. The points are not predetermined, but the points are roughly spaced evenly across the marsh plain. Transect lines are 50m apart. Transect positioning is based on individual marsh characteristics (i.e. accessibility, channel location, etc.). Marshes have an equal number of elevation points per unit area. Small marsh features were not mapped, for example channels and interior levees. Channels are digitized using ArcGIS and photos.



#### Data Processing

For each site, levee points are excluded. For the sites with randomly collected elevation points, points are excluded when they were clumped (<10m apart). For a pair of close points, the point with the highest 3D error is removed.

The points are then randomly divided into 2 subsets, 70% for a test model and 30% for validation. Hawth's tools is used to select a random subset of points (Sampling Tools->Random Selection within Subsets).

The distance among all points at a site are calculated with the Point Distance tool (Analyst Tools->Proximity->Point Distance). This can also be done by using the Measure tool between the two furthest points. This distance is used in calculating the lag size and number. Following an ERSI rule of thumb: lag size\*lag # < 1/2 maximum distance among points. If you leave the Lag # to the default 12, then dividing the maximum distance between points by 24 will give you the Lag number.

#### Ordinary Kriging

Two kriging interpolations are modeled for each site, one with 70% of the points, which were tested with the remained 30%, and one with all points included.

### ***Model Settings***

Open the Geostatistical Wizard within Geostatistical Analyst, chose the Kriging method, select the point layer and attribute you want to interpolate (ortho height).

Step 1. No transformations were performed, click next.

Step 2. Select the Exponential model. Anisotropy, which assumes a trend in the data, was turned on for all models. Set lag # to between 9 and 12, with lag size varying among sites depending on the maximum distance. Lag # can be optimized by minimizing the root-mean-square value provided in the internal cross-validation of geospatial analyst (click Next twice to get to the cross-validation screen).

Step 3. The number of neighbors included depends on how many points were at a site. For small sites, 5 neighbors are included, medium sized sites have 10, and large sites have 25. A minimum of 2 neighbors are always included. The default sector type should be left alone (four sector with 45 degree offset). The more neighbors included into the model, the more uniform the predicted surface will be as anomalous high or low points will be smoothed out. This is desirable for relatively flat places (marshes) but not so for heterogeneous terrain (mountains). Experiment with different number of neighbors and compare the root-mean-square value to determine the optimum number.

Step 4. Examine the root-mean-square value, lower is better. Click Finish to create the predicted surface. Save the output as a raster (right click on layer->Data->Export to Raster). Change the cell size to the chosen resolution of your study and then clip to the outline mask of the study site. The 'Spatial Analyst->Extraction->Extract by Mask' tool also works to clip a raster, and seems to be better at lining up the raster cells across layers.

In the original output, you can go back to examine the parameters of the model (Right-click->Method Properties)

### ***External Cross-Validation***

The krig model made with the 70% of points is converted to a raster and then extracted (using the Extract to Points tool) to the subset of 30%. The absolute value of the difference between predicted heights from the model and the ortho heights is averaged, providing a metric of model accuracy.

After verifying the model accuracy with external cross-validation, rerun the model with all points, using the same parameters.

## 13.3 Channel Cross-section Standard Operating Procedures

*Suggested citation: US Geological Survey. 2011. Channel cross-section standard operating procedure. Unpublished protocols. USGS, Western Ecological Research Center, San Francisco Bay Estuary Field Station, Vallejo, CA.*

*Disclaimer: Any use of trade, product, or firm names in this publication is for descriptive purposes only and does not imply endorsement by the U.S. government.*

### **Purpose/Objective:**

Channel cross-sections provide useful information on the development and geomorphological changes to tidal channels over time. A line is stretched from bankfull to bankfull perpendicular to the channel flow, and depths from the line to the channel bottom are measured every 0.5 meters along the line. Measurements can also be made with a laser level (Hood 2010).

### **Equipment:**

2 – 4 to 5 foot lengths of 1.5 inch PVC  
 Rubber Mallet or Hammer  
 2 – Wooden stake  
 Flagging  
 Long line  
 Torpedo line leveler

Measuring Tape  
 Measuring Stick  
 Laser level  
 Data Book  
 GPS  
 Waders  
 If needed: boat and life vests

### **Methods:**

1. Determine bankfull of channel by using clues such as vegetation type, wrack line, channel shape etc. Envision where the water line would be just before topping the banks of the channel into the floodplain. From bankfull on each side of the channel, measure an additional 5 meters from the bank, these will be your channel endpoints. You can place these endpoints farther from the bank if needed to ensure that they will not be washed out by erosive forces.
2. Install a 6 foot PVC pole 2 to 3 feet into the ground at your endpoints on either side of the channel. Mark with a wooden stake and flagging (Figs. 1 and 2). Coordinates for endpoints should be recorded using a GPS, preferable with differential correction.
3. Tie a strong, long line to one of the PVC markers. Push the line down so that it is at the surface of the soil on the base of the marker. If you are using a laser level, skip to step 5.
4. Stretch the line taut across the channel and attach to the other PVC marker at the base. Use the torpedo line level placed on the center of the line to make sure the line is level. You can adjust the line up or down the PVC markers to ensure a level line. Measure and record the distance from the top of the endpoint marker to the level line on both banks. These data will be used to determine the elevation of the level line once the endpoint markers have been surveyed.
5. Stretch the tape measure across the channel and attach to the PVC makers with the start of the tape on the east bank.
6. Starting at 0 meters, use the measuring stick to measure the depth of the channel from the channel bottom to the level line at every half meter across the channel. If the channel bottom is soft, try to place the base of the measuring stick just on the surface of the sediment. Make sure you are measuring to the level line as opposed to the tape measure. If you are using a laser level, the laser detector attached to the measuring pole will be moved up and down the pole until it reaches the level of the laser. The readings on the measuring pole will be recorded when the detector is at the same height as the laser level.
7. After making your way across the channel, measure the total width of the channel.

# TNC PSB Restoration Monitoring Plan

- The tops of the channel endpoint markers need to be surveyed so that data can be corrected to elevation. Subtract the distance from the elevation at the top of each endpoint marker to the level line to determine the elevation of the line. Then subtract the depth at each channel measurement from the level line elevation to determine the sediment elevation at each point along the channel.

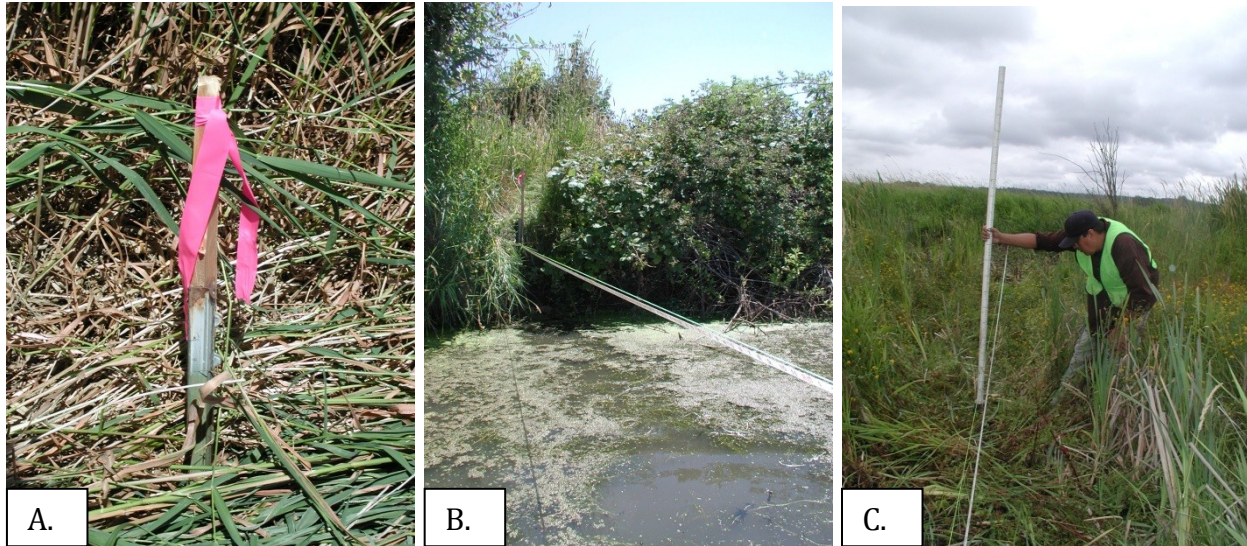

Figure 1. Channel cross-section techniques. a. PVC marker. b. Taut line and measuring tape stretched across channel. c. Measuring depth from channel bed to taut line.

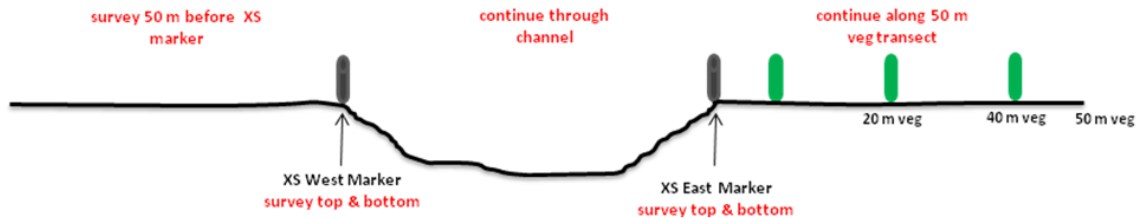

Figure 2. Diagram of cross-section

### Entering Data:

- Enter data in Excel as outlined in Table 1 below.

Table 1. Template for entering channel cross-section data.

Date	Unit	Location	StartingBank	Distance	Height	TI Width	Notes			
8/6/2009	1	North	East	0	0.03	67.4	Wide, shallow channel near front dike.			
8/6/2009	1	North	East	0.5	0.23					
8/6/2009	1	North	East	1	0.50					
8/6/2009	1	North	East	1.5	0.55					
8/6/2009	1	North	East	2	0.59					



## 13.4 Vegetation Transects and Survey Plot Standard Operating Procedures

USGS Western Ecological Research Center SFBE

*Soil Salinity and Survey Plot methods adapted from a modified version of: Carlisle, B., M. Carullo, J. Smith, C. Wigand, R. McKinney, M. Charpentier, D. Fillis, , and M. Stolt 2006. Rapid method for assessing estuarine (salt) marshes in New England version 1.4 – October 2006. Modified by: Hilary Neckles and Glenn Guntenspergen USGS, Patuxent Wildlife Research Center*

*Suggested citation: US Geological Survey. 2011. Vegetation standard operating procedures. Unpublished protocols. USGS, Western Ecological Research Center, San Francisco Bay Estuary Field Station, Vallejo, CA.*

*Disclaimer: Any use of trade, product, or firm names in this publication is for descriptive purposes only and does not imply endorsement by the U.S. government.*

### **Purpose/Objective:**

Vegetation monitoring will indicate the presence and potential source populations for restored areas. Vegetation sampling, paired with aerial photography, habitat digitization, and bathymetric data will provide a project-scale temporal and spatial understanding of estuarine processes after restoration actions.

### **Equipment:**

Compass	Transect locations/UTMs
GPS unit	Sharpie
Boots	Data sheets (Table 4)
.25 m <sup>2</sup> quadrant	Clipboard
Tape measure 50+ m	Pencils
Veg stick (round pole with centimeter increments written on it)	Plant list
Map of veg transects	Digital camera
	Binoculars
<b>Soil Salinity</b>	Filter paper (cut-up coffee filters can be used)
Hand-held refractometer	Plastic squeeze bottle with freshwater to rinse and calibrate refractometer
Trowel or small shovel	
Eye dropper	

### **Methods:**

1. Vegetation surveys are done annually in August.
2. Vegetation transects are sampled for both permanent and circle plot vegetation surveys (Figure 1). Each transect starts along a channel's edge at the channel cross section marker. The transect stretches 50 meters perpendicular to and away from the channel. Three different vegetation surveys are conducted along this transect, a permanent transect along the first 50 m, a community and habitat survey in a 100 m diameter survey plot, and a land use survey in a 150 m diameter survey plot (to be done in office). Detailed instructions for the all surveys are given below along with the order of operations to complete both surveys efficiently.

3. Transects are numbered based on their hydrologic unit and the location along that unit (i.e. North, Middle, or South).

4. The beginning of each transect is marked with a PVC pole labeled with a wooden stake and/ or short PVC. This is also the channel cross-section marker and will be located on the channel's edge at channel bankfull.

5. Each transect has a compass bearing that should be used to ensure that the tape measure is laid perpendicular to the channel. From the starting point, the person that is stretching out the tape should use the compass bearing to sight a spot on the horizon and stay on this bearing until reaching 50 meters. To avoid trampling vegetation, walk to the left side of the transect. At 50 meters pull the tape taut and lay it down or attach it to a temporary wooden stake.

6. Walk back to the start of the transect and join your field partner. You will work together to complete the 50 m permanent vegetation transect. Use the Vegetation Survey form (Table 1) to record data. Two different types of observations will be taken along the permanent transect; point intercept and quadrats. Walk along the left side of the tape and measure on the right side of the tape.

7. Point intercept data is recorded at 1m intervals starting at 0m and ending at 50 m. Place the vegetation stick so it intercepts the tape measure on the right side and hits the ground. Record the tallest species hit by the vegetation stick and the height of this species. Round the height up to the nearest cm. If a plant, such as a tree, is taller than the vegetation stick, estimate the height and write in the notes that an estimate of height was made.

8. Species are recorded as 4 letter codes. Include “non-species” such as; bare ground, litter, mudflat, etc (Table 2). Note that for any of these “non-species” that are recorded, no height measurement is needed.

9. Any species that are not identifiable by the observers should be collected as a voucher specimen for further identification purposes and given a number for the survey, until they are properly identified. DO NOT collect plants within the quadrat or along the transect, rather find the same unidentifiable plant nearby to collect. Collect all parts of the plants including roots, place in a baggie and label a temporary code, the date, and the transect it was collected. However, do not collect plants that are growing sparsely in case they have low populations. If you come across this type of plant, use the digital camera to take a close-up picture and record any notes or observations on the plant's growth form, habitat, and characteristics.

10. Quadrat data is collected at 0, 19.5, and 39.5 meters. Set the .25 m<sup>2</sup> quadrat on the right side of the tape measure. The right edge of the quadrat should be lined up with the sampling location along the tape (i.e. 0, 19.5 or 39.5). The species name, absolute percent cover, rooted stem count,

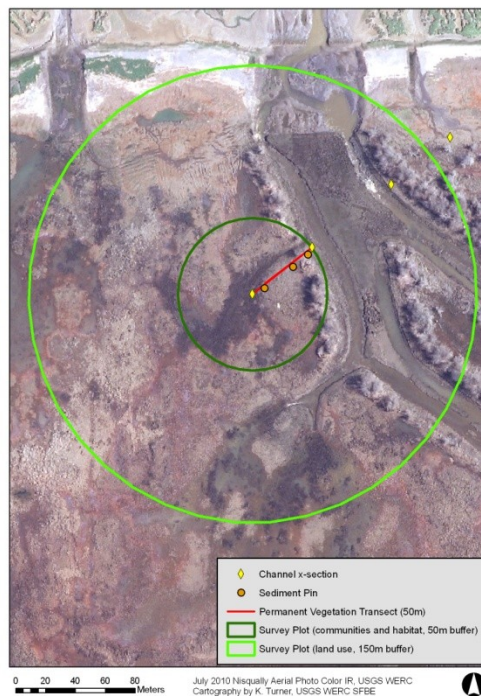

Figure 1. Vegetation monitoring station. Unit 1 North, Nisqually, WA.

and the maximum height for each species in these quadrants is recorded. Record all species found in the quadrants as well as non-species.

- If standing water is present, measure the deepest water depth within the quadrant (record under WD), but do not include standing water in the percent cover.
- To estimate percent cover, first record the four letter code for all species and non-species present. Include all plant material intercepting the quadrant area, not just plants rooted in the quadrant. Make ocular estimates of the percent cover for each species etc. When percent cover for all species, etc. are estimated, sum these estimates. If the sum is less than 100%, reconsider estimates. However, due to different canopy layers, total percent cover can exceed 100%. Use the Percent Cover guide (Figure 2) to help with estimates.
- Height is measured from the substrate to the top of the tallest individual of each species in the quadrant. Record to the nearest cm.
- Stem counts (densities) are done by counting the rooted stems of individual plants inside the quadrant. This measurement is used to report the density of individuals per square meter for each species. If plant foliage is present in the quadrant, but the plant is rooted outside of the quadrant, record 0 as stem count. Stem density is most often used for woody species where the stems are easily discernable. In salt marsh habitats, the stems can be difficult to discern. When counting stems in the salt marsh habitat it is best to try and locate the base of each plant and count each base as one individual stem. When this is not possible without damaging the plants, then estimations in the field based on the individual circumstances must be made. **In these circumstances, make sure to write down your method for counting in the notes.**
- There are many grass species that may be growing so densely in the quadrant that only a sample of the stems need to be counted and a total count can be estimated, based on the relative size of the sample compared with the total percent cover of that species.

11. Soil salinity is measured in conjunction with salt marsh vegetation quadrats in all marsh units. Salinity data can aid understanding some of the fundamental causes of vegetation change. Soil salinity is measured adjacent to vegetation quadrats. These measurements are taken using substrate extracted water and a refractometer.

- Sampling should coincide with vegetation quadrat sampling.
- Calibrate (zero) hand-held salinity refractometer with fresh water (tap water is okay) before EACH field day.
- At a location near the vegetation quadrat a small shovel is used to create a pooling of water to sample from. This is done by pushing the shovel into the ground and wiggling it back and forth a few times.
- If the water is not pooling around the shovel then a handful of substrate can be extracted and the water squeezed out into the coffee filter. (Multiple handfuls of substrate can be used in order to gather enough water to filter through the filter.)
- The extracted water should pass through the filter paper and onto the glass plate of the refractometer. If there is not enough water to go through the coffee filter then a few drops can be tested without filtration, which is better than no reading at all. (The drops can be placed straight onto the refractometer, the reading line will be fuzzy and a best estimate will have to be made)
- Be sure to record if the water was collected from the pooled or hand squeezed method, if filtration was or was not successful, and record “dry” if no water can be extracted.
- Read and record the soil water salinity (ppt) on the data sheet.

- Clean-up. Discard (never re-use) the filter paper. Rinse refractometer with freshwater.

12. Once you have reached the end of the permanent transect at 50 m you will complete the 100 m diameter survey plot for generalized community and habitat classifications.

The area of interest is a 100m diameter circle plot around the Survey Point. The Survey Point is the 50m point at the end of the permanent transect.

13. Two GPS locations are provided for the Survey Plot: the Center Survey Point and a Perimeter Point. The Perimeter Point starts the 50 meter vegetation sampling transect and the Center Survey Point will be the end of the vegetation transect. Create the 100m diameter of the circle plot by walking out an additional 50 meters along the compass bearing from the end of the vegetation transect to the other side of the Survey Plot. Examine the interior of the 100m Survey Plot as a team. Each person examines one half of the plot by walking the perimeter and scanning (you can use binoculars) as well as using an aerial photo with the 100 meter circle plot placed on it. Try to get a good view of this circle plot while minimizing the disturbance of the vegetation. After examining the plot the team will meet up and discuss what was found on each half, and calculate the cover classes of the entire 100 meter plot.

Look for the following plant communities and open water features (community types associated with low and high marsh will vary by region):

- *Jaumea carnosa* or *Carex sp.*-dominated (“Low Marsh”)
- *Deschampsia caespitosa*-dominated (“High Marsh”)
- Salt Marsh Terrestrial Border
- Brackish Terrestrial Border
- Invasives
- Pannes, Pools, Creeks and Mudflats
- Open Water
- Upland

14. Using the Percent Cover guide (Fig 2) and the table below, estimate the cover for each of the above communities. Fill in the cover class and note dominant species on the Survey Plot data sheet- Plant Communities and Habitats (Data Sheet B).

Cover classes:

+: Absent or Less than 1%

1: 1% to 5% cover

2: 6% to 10% cover

3: 11% to 25% cover

5: 51% to 75% cover

6: 76% to 100% cover

15. Leave the Land Use table for the 100-m buffer around the Survey Plot blank, this data will be determined in the office using GIS and the protocols below.

### **100-m buffer around Survey Plot**

These data are intended to characterize the land use at the Survey Point, so that the condition data collected at the Survey Point is tied more closely to land use disturbances. Land use in the buffer zone of the Survey Point is classified into eight types:

## TNC PSB Restoration Monitoring Plan

- Natural condition: Undisturbed natural area of buffer, including shrub, forest, meadow, wetlands, open water, etc.
- Modified natural condition: managed marsh (e.g. OMWM, impoundment, tidally restricted)
- Maintained open: Parks, golf courses, cemeteries, public green space, vacant undeveloped land, abandoned agriculture, power lines, areas of no vegetation, etc.
- Disturbed open: Sand, gravel, and rock mining; landfills; etc.
- Agricultural: Pasture, cropland, cranberry bogs, nurseries, etc.
- Residential - Low: greater than ¼ acre lots
- Residential - High: smaller than or equal to ¼ acre lots
- Urban: Urban areas including commercial buildings, industrial parks, apartments, shopping centers/malls, airports, roads and highways, freight, storage and stadiums.

Using the base map, look in a band approximately 100-m wide around the perimeter of the Survey Plot and examine the types of land uses present. Using the Percent Cover guide (Fig 2) and values below, estimate the cover for each of the above land use types. If your base map has land use data, make sure what you see in the field corresponds and if necessary, override the mapped land use types with current information. On the Survey Plot data sheet – Communities and Habitats (Data Sheet B), mark the cover class for the extent of each land use type present.

Cover classes:

+: Absent or Less than 1%

1: 1% to 5% cover

2: 6% to 10% cover

3: 11% to 25% cover

4: 26% to 50% cover

5: 51% to 75% cover

6: 76% to 100% cover

Table 1. Codes for non-species

Other Codes		Height and Stem Density
ALGB	Brown Algae	N/A
ALGG	Green Algae	N/A
BARE	Bare ground	N/A
SEDWR	Sediment Wrack – sediment layer that is covering DOM, LI, or WR. Note this is different than BARE.	N/A
DOM	Dead & standing plant material	N/A
LI	Litter - dead & <b>not</b> standing plant material	N/A
WR	Wrack – living or dead plant material that floated in with tide	N/A
MF	Mudflat	N/A
OPWA	Open Water	N/A
UNKN	Unknown	N/A



# TNC PSB Restoration Monitoring Plan

## Vegetation Sampling Form - Permanent Transects / Quads

Date \_\_\_/\_\_\_/\_\_\_ time \_\_\_:\_\_\_ Obs \_\_\_\_\_ Site \_\_\_\_\_ Transect \_\_\_\_\_

UTM (transect) \_\_\_\_\_ / \_\_\_\_\_ Compass Reading \_\_\_\_\_

Point	Spp	Height (cm)	Point	Spp	Height (cm)	Point	Spp	Height (cm)	Point	Spp	Height (cm)
0.0*			13.0			26.0			39.0		
1.0			14.0			27.0			40.0*		
2.0			15.0			28.0			41.0		
3.0			16.0			29.0			42.0		
4.0			17.0			30.0			43.0		
5.0			18.0			31.0			44.0		
6.0			19.0			32.0			45.0		
7.0			20.0*			33.0			46.0		
8.0			21.0			34.0			47.0		
9.0			22.0			35.0			48.0		
10.0			23.0			36.0			49.0		
11.0			24.0			37.0			50.0		
12.0			25.0			38.0					

\*remember quad

<b>0.0</b>							
<b>Quad 1</b>	<b>m</b>	<b>Soil Salinity ppt _____</b>					
<b>WD _____</b>		<b>Comments _____</b>					
<b>Species</b>	<b>%</b>	<b>Ht.</b>	<b>Dens</b>	<b>Species</b>	<b>%</b>	<b>Ht</b>	<b>Dens</b>

<b>19.5</b>							
<b>Quad 2</b>	<b>m</b>	<b>Soil Salinity ppt _____</b>					
<b>WD _____</b>		<b>Comments _____</b>					
<b>Species</b>	<b>%</b>	<b>Ht.</b>	<b>Dens</b>	<b>Species</b>	<b>%</b>	<b>Ht</b>	<b>Dens</b>

<b>39.</b>							
<b>Quad 3</b>	<b>5m</b>	<b>Soil Salinity ppt _____</b>					
<b>WD _____</b>		<b>Comments _____</b>					
<b>Species</b>	<b>%</b>	<b>Ht.</b>	<b>Dens</b>	<b>Species</b>	<b>%</b>	<b>Ht</b>	<b>Dens</b>

Comments, diagrams, etc.:

### Survey Plot- Communities and Habitats

# TNC PSB Restoration Monitoring Plan

**Site:** \_\_\_\_\_ **Transect** \_\_\_\_\_ **Date:** \_\_\_\_\_ **Time:** \_\_\_\_\_ **Tide:** \_\_\_\_\_ **Obs:** \_\_\_\_\_ **Center GPS**

**Coordinates (50m): Northing** \_\_\_\_\_ **Easting** \_\_\_\_\_

Cover classes: +(<1%)   **1**(1-5%)   **2**(6-10%)   **3**(11-25%)   **4**(26-50%)   **5**(51-75%)   **6**(76-100%)

Communities and Habitats in 100m Diam. Survey Plot	Cover class	Dominant species
<u><i>Jaumea carnosa</i> or <i>Carex sp.</i> dominated ("low marsh")</u> Regularly flooded by daily tides; Highly saline conditions are dominated by <i>Jaumea carnosa</i> and <i>Salicornia virginica</i> Brackish conditions are dominated by <i>Carex sp.</i> , <i>Triglochin maritimum</i> and <i>Scirpus sp.</i> Common species include <i>Distichlis spicata</i> , <i>Plantago maritima</i> , <i>Spergularia sp.</i> and <i>Atriplex patula</i> .		
<u><i>Deschampsia caespitosa</i> dominated ("high marsh")</u> Above mean higher high water; and inundated less than daily; Dominated by <i>Deschampsia caespitosa</i> , and <i>Hordeum brachyantherum</i> Common species include <i>Distichlis spicata</i> , <i>Grindelia integrifolia</i> , <i>Potentilla anserina ssp. pacifica</i> , and <i>Atriplex patula</i>		
<u>Salt marsh terrestrial border</u> Infrequently flooded by spring and storm tides; Moderately halophytic; Could include areas of higher elevation on marsh platform (commonly islands or linear patches next to channel edges) Dominated by <i>Aster subspicatus</i>		
<u>Brackish terrestrial border</u> Rarely flooded by tides, but often tidal influenced fresh/brackish Not halophytic but tolerant of maritime conditions (spray and infrequent pulses) Includes areas heavily influenced by freshwater sources. Dominated by <i>Typha Latifolia</i> , <i>Salix sp.</i> and <i>Populus sp.</i> Could include <i>Spiraea douglasii</i> and <i>Physocarpus capitatus</i>		
<u>Invasives</u> Invasives such as <i>Phalaris arundinacea</i> , <i>Cotula coronopifolia</i> , <i>Lotus corniculatus</i> , <i>Cirsium sp.</i> , and <i>Ranunculus sp.</i> Colonization and spread often result of disturbance		
<u>Pannes, Pools, Creeks, and Mudflats</u> Channels, creeks, ditches, pannes, pools and mudflats		n/a
<u>Open Water</u> Larger areas of water: bays, rivers, ponds		n/a
<u>Upland</u> Non-wetland areas of upland that fall into the 100m diameter circle; includes land uses of all types (e.g. natural and developed) Dominated by Conifers such as <i>Pseudotsuga menziesii</i> & <i>Thuja plicata</i>		n/a

**100m Buffer around Survey Plot – to be completed in office**

Land Use Type	Cover Class	Land Use Type	Cover Class
Natural condition		Residential – Low	
Modified natural		Residential – High	
Maintained open		Urban	
Disturbed open		Marina	
Agricultural			

Figure 2. Percent Cover Guide

1% to 5%: These are all 5% cover

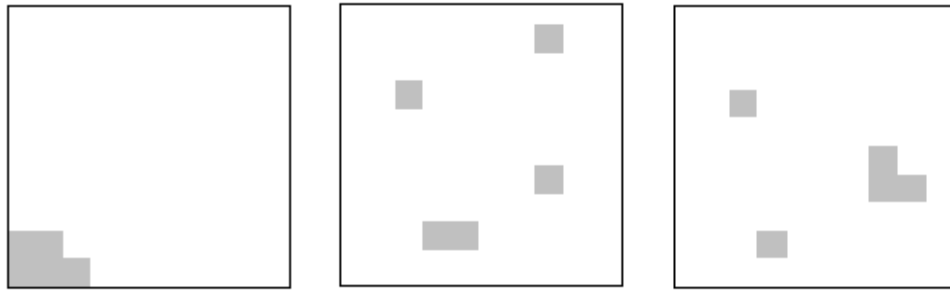

6% to 10%: These are all 10% cover

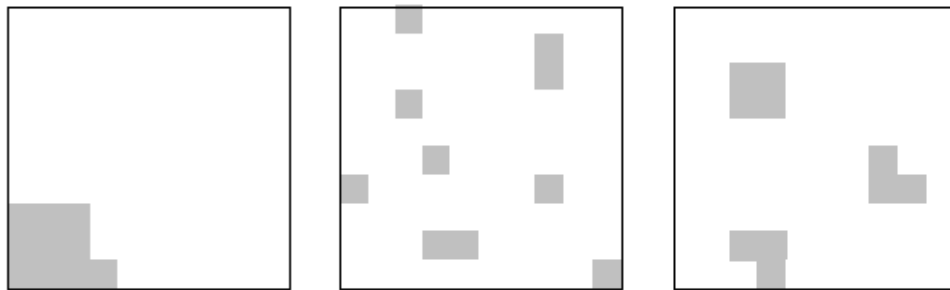

11% to 25%: These are all 25% cover

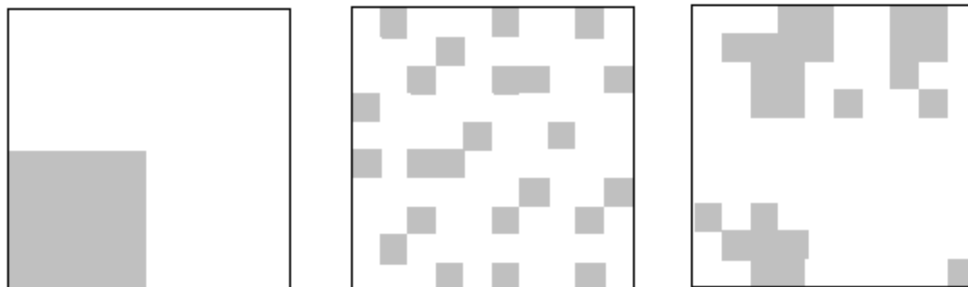
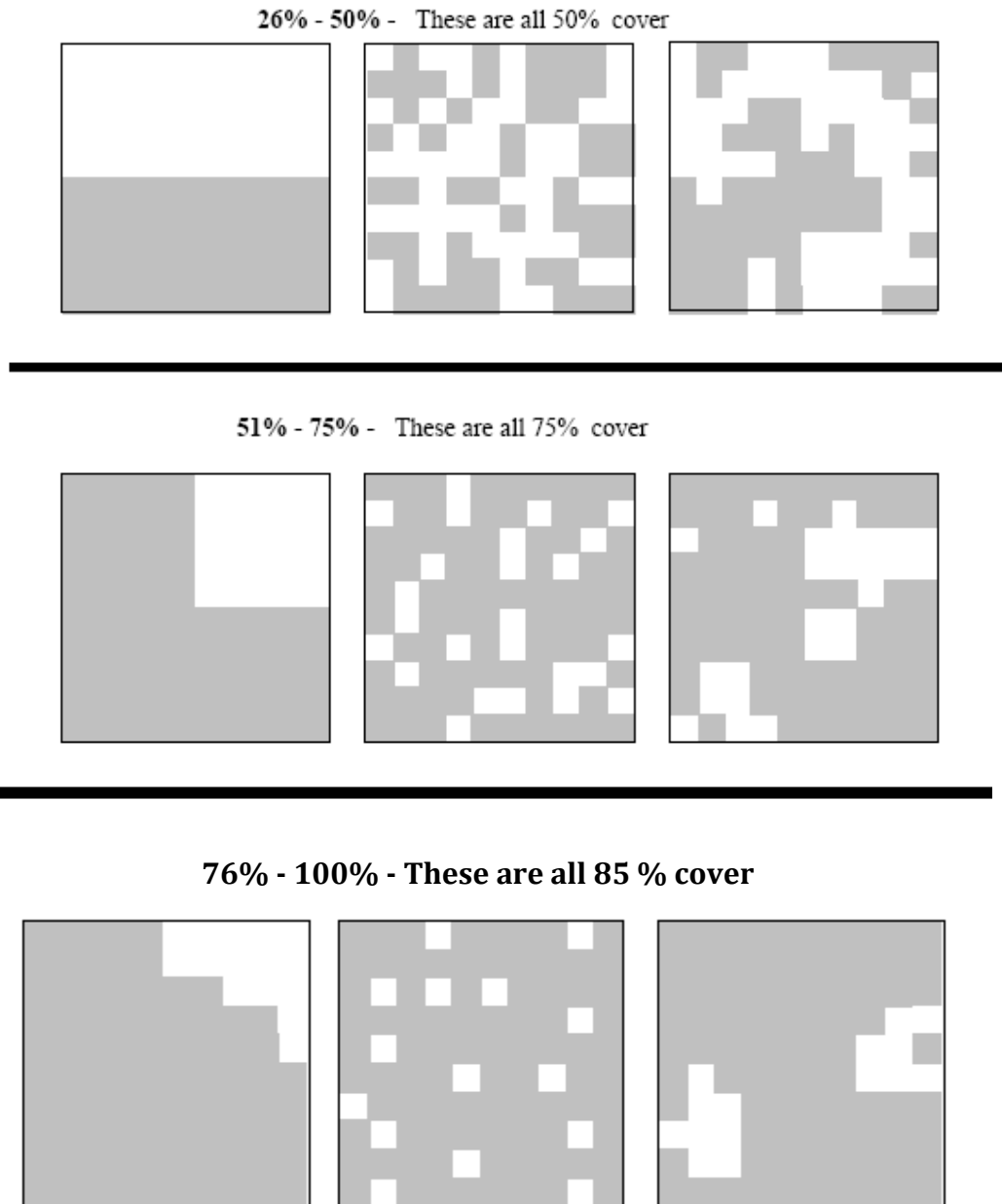

Figure 2 cont.



## 13.5 Continuous Water Level, Temperature and Conductivity Standard Operating Procedures

*Suggested citation: US Geological Survey. 2011. Water level and quality, continuous standard operating procedures. Unpublished protocols. USGS, Western Ecological Research Center, San Francisco Bay Estuary Field Station, Vallejo, CA.*

*Disclaimer: Any use of trade, product, or firm names in this publication is for descriptive purposes only and does not imply endorsement by the U.S. government.*

### **Purpose/Objective:**

Tidal prism is a key indicator of sea level rise, and it is a primary driver of habitat type and distribution, in both natural and restored estuarine wetland settings. Water level loggers are programmed to operate in a continuous monitoring mode, collecting data at user defined intervals and storing the data until it is downloaded in the field. We suggest the use of Solinst LTC loggers to measure continuous temperature and conductivity data along with water level. These data can be used to calculate salinity, and together, provide the key water quality parameters important to estuarine biological communities.

### **Equipment:**

#### **Programming and Calibration**

Solinst Levellogger  
 Levellogger Optical Reader  
 Computer with USB port or Solinst  
 Leveloader  
 Solinst Levellogger Gold Software 3.4.1  
 Conductivity standard (MUST be 1413, 5000,  
 or 12880  $\mu\text{S}/\text{cm}$ )  
 Distilled water  
 Calibration cup (found that the case the  
 logger is shipped in works well)  
 Solinst user guide

#### **Field Download, Calibration, and Maintenance**

Programming and Calibration Equipment	
Notebook/Datasheet	1 -2 packages of 1/8" stainless steel clamp sets
Pencil	Stainless steel cable
Sediment measuring pole	Wire cutters
Compass	Umbrella (if raining to protect computer)
Pliers (two pair is helpful sometimes, one being needle nosed)	Bucket (use as table in deep water site)
Small pipe cleaner for levellogger	
Papertowels	
Pantyhose	
Zip ties	
Scrub brush (for staff gauge)	
Backup Supplies:	
WD 40 or other lubricant	



## Methods:

### **Levelogger Installation**

Methods for levelogger deployment will vary by site. Considerations include: sampling intent (i.e. full tidal range vs. marsh inundation time), logger location (i.e. river, tidal channel, or marsh plain), method of access (i.e. boat on high tide vs. foot on low tide), substrate type, and potential threats to instrument (i.e. logs, *Ulva sp.*, boats). For most purposes, installation includes driving a length of fence post into the ground to which the logger is attached, either directly to the post or in a protected PVC pipe. It is critical that the logger be returned to the same location within the water column after each download so that water depth data can be converted to a tidal datum. Otherwise, the elevation of the logger must be surveyed during every download.

### **Solinst Levelogger Programming**

Before deploying a levelogger for the first time, the logger settings must be set by directly connecting the logger to a computer using the USB logger optical reader. First connect the device, and then open Leveloader 3.4.1. From the home screen, select “**USB Serial Port**” from the Com Port Selection drop-down list. Then, Click the “**Receive Settings from Levelogger**” button.

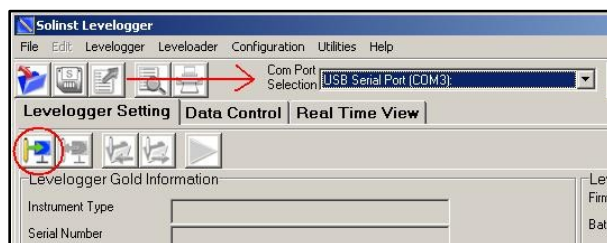

The current settings from the levelogger will then be displayed, adjust as follows:

Project ID = enter project site

Location = enter the name of the channel the logger will be deployed at

Altitude = site specific (feet)

Density adjustment = keep default settings

Memory mode selection = select preference. Slate Logging Mode records data until the device fills up (31999 readings) and then stops recording; Continuous Logging Mode records data continuously such that if the memory fills up, it overwrites the oldest data.

Sample rate = set preference

Conductivity tab should be set to specific conductance.

Level tab = keep default settings (m)

Temperature tab = keep default settings (Celsius)

Time Synchronization = select enable to synchronize to the computer's time stamp, then click “synchronize”

The start time should be on the hour.

To apply these changes hit the icon that shows the arrow from computer to logger (program settings to logger).

### **Conductivity Calibration**

Calibrate the logger by clicking the calibration wizard icon, which will guide you through the process.

1. Rinse the logger with distilled water and a bit of calibration solution. Plug into the optical reader.
2. Thoroughly mix the calibration standard by slowly flipping the bottle end over end. Avoid creating bubbles.
3. Triple rinse the calibration cup with conductivity standard.
4. Fill the calibration cup up halfway with conductivity standard.

5. Place the sensor end of the levellogger into the calibration cup so that it is completely submerged.
6. Keep the optical reader connected to the levellogger.
7. Lightly tap the sides of the calibration cup to remove bubbles.
8. Allow the logger to sit in the solution for 2-3 minutes then hit calibrate. If calibration fails it is most likely due to tiny bubbles somewhere, so tap it some more and try a couple more times before using new solution.

**NOTE\* The calibration standard must be at 10 degrees Celsius, and remain at that temperature for the duration of the calibration procedure. Failure to keep the solution at or above this temperature will result in a failed calibration result.**

### ***Post Calibration – DO FIRST IF DOWNLOADING DATA***

Prior to re-calibrating the levellogger after downloading data in the field, you must first obtain a post calibration reading for quality control assurances that the logger is measuring accurate conductivity.

1. Remove the logger from the PVC pipe.
2. Rinse the logger with distilled water and a bit of calibration solution. Remove the cap of the logger to reveal the probes. Plug the probes into the USB port. Plug the USB port into the laptop.
3. Open the Solinst 3.4.1 program. Select the COM Port to from the drop down menu at the top center of the screen.
4. Open the Utilities drop down menu and Select Diagnostic Tools.
5. Select the Read Levellogger Info button (first button at the bottom of the screen) to obtain a reading of current logger settings. This should then show a current temperature and specific conductance. Record the specific conductance reading on the datasheet. The manufacturer suggests the pre-calibration conductance value should not vary by more than 2% from the known concentration of the solution, or a calibration is required, though calibration is recommended more frequently in brackish water settings, even if the logger is reading within 2%.
6. Return to the main screen and stop the logger (stop sign button). Calibrate conductivity by using steps above.

**NOTE:** If you feel the logger is not functioning properly you may also run a diagnostic test from this screen. Select the Run Self-Test button, the second button in the Diagnostic Tools window. The result will be a green check mark for each of the nine categories listed if everything is working properly. You may save a copy of this report to refer to later if you then select the Create Report button and fill in the required information. Be sure to save with the levellogger's location as the name of the report to the laptop.

### ***Solinst Levellogger Download using Solinst Leveloader***

Data recorded onto the levelloggers must be downloaded before the unit reaches capacity (31999 readings). This will depend on the frequency with which data points are recorded. With a sample rate of 6 minutes, LT loggers can run for approximately 133 days before they reach maximum capacity. LTC loggers reach maximum capacity sooner. *To be safe, and to ensure data is being recorded correctly, loggers are downloaded approximately every 6 weeks.*

1. To download the data, unscrew the logger cap and attach the leveloader to the levellogger via the optical cable.
2. Once attached, turn on the leveloader by holding down the "On" button for a couple seconds.

3. Use the arrow keys with three lines to select menu options, and use the arrow keys with up and down arrows to cycle through those options. From the main menu, select “**Connect to Logger**”. It is not uncommon at this point to receive a “Check Communication Cable” error message. Ensure that the cable is firmly connected to both the logger and the leveloader (more often than not, it is a problem with the connection at the leveloader end).
4. If there is no error, you will see the Levelogger Menu with the option “**Data from Levelogger**”. Select and you should see a few data points and an option to “Save Log”.
5. Select “**Save Log**” to download the data to the leveloader. A progress bar will appear indicating the download has initiated. If the “Check Communication Cable” error occurs at any point during the download, the data will not be stored and you must restart the download. You will see “**Download Completed!!**” once the download has finished successfully.
6. After downloading the data, the logger must be stopped, the stored data on the logger must be erased to make room for future data, and the logger must be restarted and synchronized with the other deployed loggers. Scroll down and select “**Restart Levelogger**” from the Levelogger menu.
7. From the following menu, select “**Future Start Logging**” so that you can input a specific time to start the logger. A prompt will inform you that all data will be erased. You will be prompted to stop the logger. THIS IS OK IF AND ONLY IF YOU HAVE ALREADY DOWNLOADED THE DATA! Always perform this step last.
8. Select OK and you will then be prompted to stop the logger before restarting. **Press both the up and down arrow keys simultaneously and hold them for about one second to stop the logger.**
9. You will then see a screen where you can set the date and time to start the logger. The first two lines indicate the date and time you will be setting it to start along with the date/time format. The second two lines indicate the value you are selecting to input the date and time. Scroll with the up and down arrows to cycle through the numbers. Clicking OK inputs the number selected from the third row into the highlighted slot on the first row. To advance to a new input slot, cycle through the options to the “NXT” button and select OK; the highlighted slot on the first row will advance. Continue to cycle through and select values until the date and time are input fully. The highlighted cursor should be at the end of the top row TO THE RIGHT OF THE SECONDS SLOT once all date and time information has been set. Finally, to start the logger at that time, cycle to and select “**SUBMIT**”. You should see a prompt that the logger has been started.
10. Hold the “On” button on the leveloader for a couple seconds to turn it off, unscrew it from the levelogger, and screw the black cap back onto the levelogger.

### ***Solinst Leveloader Data Download to PC***

Once the data has been successfully downloaded from the leveloggers onto the leveloader, the data can then be downloaded from the leveloader onto a PC.

1. Turn on the leveloader, connect it to a computer using the USB Communications Cable, and then run Levelogger 3.4.0 (the leveloader cannot be turned on once connected).
2. On the leveloader, select “**Connect to PC**”; you’ll see the number of stored logs and that data transfer is ready.
3. From the Levelogger software, select “**USB Serial Port**” from the Com Port Selection drop-down list.
4. To download the data, click the “**Data Control**” tab followed by the “**Leveloader**” sub tab. Finally, **click the download button indicated by the big red down arrow.**
5. After a few minutes, a window will pop up requesting you to select the destination folder for your download. The left half of the window shows all data to be downloaded, while the

right half shows the pathway where your data will then be stored. **IMPORTANT:** by default, all data on the leveloader will be transferred, even if you have already downloaded it. You must deselect the files you have already downloaded to prevent downloading data again – *downloads can take a while, so you should only download the new data you need to retrieve.* Look for the file with the logger serial number and the download date to identify the correct data to download, and click OK to start the download. A progress bar will indicate the download has initiated.

- To view the data, simply open the file you just downloaded in the Levelogger software by selecting File > Open (or by clicking the Open icon indicated by a blue folder). Prior to opening the file, you may wish to change the file name to read with greater ease, but **be sure to keep the .lev file extension.** Once opened, the data will be displayed in a table in the upper window and in a graph in the lower window. **Both the graph and table can be exported through File > Export.**

### **Barometric and Manual Data Compensation**

To convert the data into true elevation, it must be compensated for both the barometric pressure as well as the true height of the water logger.

#### **Barometric Compensation**

- To compensate for barometric pressure, first open the barometric levelogger (.lev) file that contains the barometric pressure data you will be using to compensate your other LT loggers.
- With the file open, select the “**Data Control**” tab followed by the “**Levelogger Gold Information**” sub tab, and click “**Data Compensation**” (indicated by the red arrow pointing to a logger).
- A pop-up window will request you to indicate the type of currently open file: select “**Barometric file**” and click Next.
- Another window will request you to open a *Submerged Levelogger File* (**NOT** a Barometric Logger file): select the file you wish to compensate for barometric pressure.
- A third window lets you choose the type of compensation to perform. *Check only the Barometric Compensation button and leave everything else unchanged.*
- A final window will ask you to specify a name and location for the compensated file. By default, the file name is the same as before with “Compensated” appended to the end. Leave it the same or rename it however you like – **BUT MAKE SURE YOU ADD .LEV TO THE END OF THE NAME.** Despite the fact that it says it will save it as a levelogger (.lev) file, if it doesn’t have the extension explicitly written in, it will save it as an unreadable file type.



#### **Manual Compensation**

Next, you will need to compensate for the true elevation of the logger. To do this, *you must have taken an RTK elevation point at the top of the logger and then subtracted the logger length* (for LT loggers, the length to subtract is 0.120m; for LTC loggers, the length is 0.177m).

- Open a submerged levelogger file that has already been compensated for barometric pressure, click on the data compensation button, and this time select “**Submerged Levelogger file**”
- Check “**Manual Data Adjustment**” and *make sure that “Barometric Compensation” is deselected.*
- The reference datum must be calculated as the compensation value. To calculate the reference datum, add the value for the LEVEL in the first row of data (from the data control

window in the Levellogger Software) to the value for the true logger elevation (again, this is just the RTK value for the logger minus the logger height). Input the resulting value in for reference datum and click "Next". *Pay attention to the units*, which you cannot change. The units is set to the same unit that was originally defined for the logger (m is default).

4. A window will request you to name and save the file. As for barometric compensation, the default name is just the original file name with "Compensated" appended. **MAKE SURE TO ADD .LEV TO THE FILE NAME.**

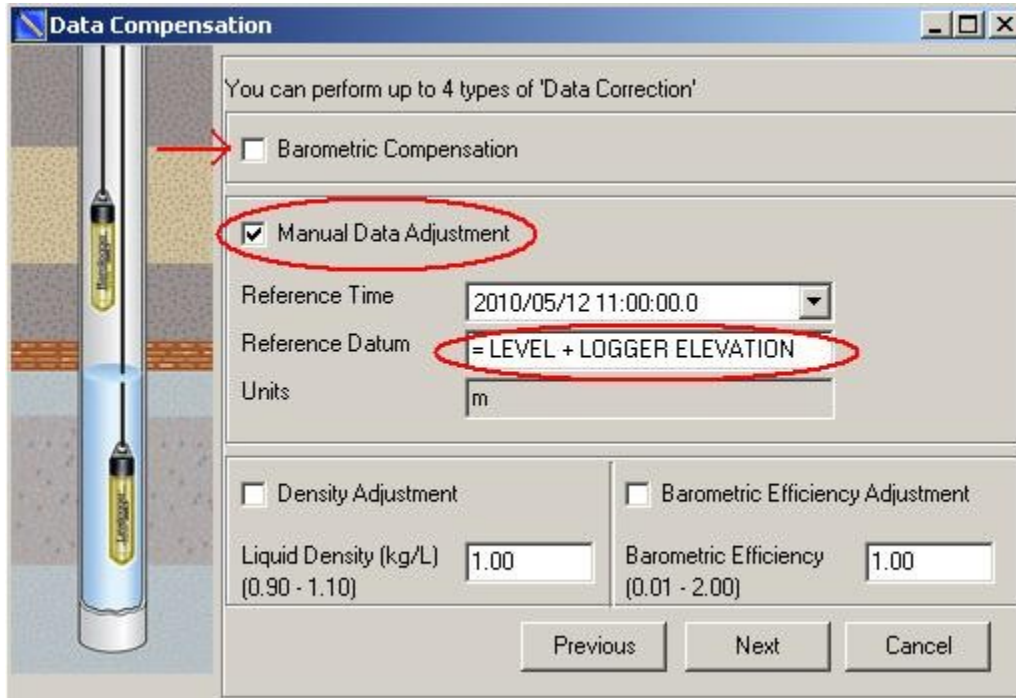

5. Export the data as a comma separated file for use in statistical programs (File > Export > Data). Data will be **exported as a comma separated value file**. When naming the file to be exported, **MAKE SURE AND ADD .CSV TO THE FILE NAME.**

# TNC PSB Restoration Monitoring Plan

<b>Water Level Logger Download Checklist:</b>	
Site: _____	Crew: _____
Date: _____	
Staff gauge reading on the fifteen minute mark: **(reading must be taken while logger in water)**	
	time: _____
	water level: _____
Time of logger removal:	_____
Pre-calibration Conductance Reading:	_____
Concentration of calibration solution:	_____
Temp Adjusted Standard:	_____
Temperature:	_____
Conductance:	_____
Time of logger redeployment:	_____
Sediment measurements (m) in the cardinal directions:	_____
	north: _____
	east: _____
	south: _____
	west: _____
Any notes about the site for next visit: _____	



## 13.6 Continuous Water Quality Standard Operating Procedures

USGS Western Ecological Research Station SFBE

*Suggested citation: US Geological Survey. 2011. Water quality, continuous standard operating procedures. Unpublished protocols. USGS, Western Ecological Research Center, San Francisco Bay Estuary Field Station, Vallejo, CA.*

*Disclaimer: Any use of trade, product, or firm names in this publication is for descriptive purposes only and does not imply endorsement by the U.S. government.*

### **Purpose/Objective:**

Water quality controls the distribution of vegetation, benthic invertebrates, and fishes. It can be affected by habitat restoration and by climate-induced changes in sea level, river flows, and ocean temperature and pH. Water quality sondes can be deployed at water level logger monitoring stations to characterize additional water quality parameters over a tidal cycle.

### **Equipment:**

Hydrolab datasonde (hand-held surveyor, cable(s), storage/calibration cup(s) and laptop - with Hydras3 LT program installed)  
 Laptop charger  
 Power converter  
 Minisonde (w/ hand-held surveyor, cable, storage/calibration cup, sampling guard and pelican case)  
 Turbidity Standards (4000 ntu)  
 pH Standards (7 and 10)  
 Specific Conductance Standards (47.6 mS/cm and 80 mS/cm)  
 Distilled water and squirt bottle  
 Barometer  
 Kim wipes  
 Insulated Drink-Style Cooler (commonly used at sporting events and can be purchased at hardware stores; often made by Igloo)  
 Data Field Notebook, Calibration / Maintenance Notebook, data sheets, clipboard, pencils and Sharpies  
 Hip boots or waders (and mudders if needed)  
 Blue towels  
 Tap water

Hydrolab DO maintenance kit  
 Hydrolab replacement LDO cap  
 Hydrolab pH maintenance kit w/ pH Teflon bridge(s)  
 Replacement seals and O-rings  
 Replacement brushes  
 Q-tips  
 Isopropyl Alcohol  
 Nylon stockings (knee-high white or cream)  
 Copper mesh (**do not use copper-coated scrub pads – only 100% copper products**)  
 Screwdrivers (2-3)  
 Padlock keys  
 Cleaning tools - toothbrush, sponge, bottlebrush, Kim wipes, tweezers and rags  
 Replacement circulator  
 Grease  
 C-Batteries (8 per instrument)  
 Hose clamps (various sizes)  
 Cable/zip ties  
 Replacement PVC holder  
 Rope  
 Dummy Plugs/Extra Plugs

### ***Datasonde Deployment / Maintenance Kit***

## Methods:

### *Field Procedures and Sampling Techniques*

1. Check equipment list and supplies prior to leaving for servicing trip.
2. Upon arrival at the station consult Calibration/Maintenance Notebook for specific instrument to determine if the instrument needs to be calibrated. Instruments should be calibration **bi-weekly** unless there are discrepancies with the data or other maintenance is to be performed.
3. Connect cable and surveyor to the instrument while it is still in the water and turn on circulator (**Setup/Cal, Setup, Sonde**, arrow to **Circulator**, select 1 to turn it on). Setup Minisonde (refer to Minisonde Sampling Techniques) and place in the water next to the Datasonde making sure that the units are at the same depth. Once both units are on, wait 2 minutes and take a simultaneous reading with both instruments (time, temperature, pH, DO, salinity, spec. cond., and turbidity) and record on data sheet ("**in pond**" reading). Readings should be similar. If the readings are not similar, take an additional reading. If readings are still inconsistent, pull unit for cleaning and maintenance.
4. If Minisonde and Datasonde readings are similar and unit does not require maintenance or calibration proceed to **Downloading Procedure**.
5. If Datasonde requires maintenance and/or calibration, turn instrument off and pull it from the pond. Use a screwdriver to loosen the hose clamps, and unlock the instrument from the deployment security device.
6. Collect one bucket of local water from area where the instrument is deployed. Rinse the buckets three times before filling.
7. Place the Datasonde and Minisonde in the bucket, turn them on, wait 2 minutes and take an additional simultaneous reading with both instruments and record on data sheet ("**initial**" reading).
8. Now the Datasonde can be cleaned. Use the toothbrush, bottlebrush, sponge, Kim wipes and Q-tip to clean the Datasonde exterior and sensors. Special care should be taken to not scratch the DO membrane / LDO cap or the conductance sensor – use only Kim-wipes and Q-tips to clean. Also **DO NOT** rotate the self-cleaning brush unit at any time. **Additional care should be taken to NOT expose the units with LDO sensors to direct sunlight. All cleaning of these units should take place in a shaded location.** During cleaning you should inspect the DO membrane for scratches, bubbles or holes. If any of these exist replace the DO membrane. If there are scratches on the surface of the LDO cap it should also be replaced. Refer to manual for this procedure. The pH Teflon bridge should be checked with each cleaning and electrolyte should also be checked and replaced at least bi-monthly. Refer to manual for procedures for both of these functions. Be sure to make notes of all cleaning and maintenance in the Calibration/Maintenance Notebook.
9. Once the Datasonde is cleaned it can be placed in the bucket with the Minisonde. Turn the Minisonde and Datasonde on, wait 2 minutes and take an additional simultaneous reading with both instruments and record on data sheet ("**de-fouled**" reading). Turn off both instruments and leave them in the buckets. Now the Datasonde is ready to be downloaded.

### *Downloading with a Laptop Computer*

1. To download the Datasonde with a laptop first you need to turn on the laptop and disconnect the Surveyor from the Datasonde. Connect the communication cable to the laptop and initiate the Hydras3 LT program by double clicking on the icon on the desktop of the laptop. This should bring up the following screen: The Datasonde should appear in the **Connected Sondes** window.

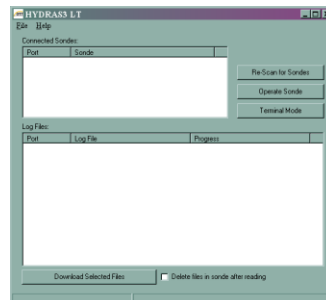

If it does not, press the **Re-Scan for Sondes** button as many times as necessary. If you continue to have problems connecting check the connections for both the laptop and the Datasonde. Once the Datasonde is connected the log file for the pond should appear in the **Log Files** window. Select the file and press the **Download Selected Files** button. It can take 1-10 minutes for the file to download depending on size. New log files should be created every 2-3 weeks to prevent slow download times. Once the file is downloaded it should be checked to make sure it is complete and also that there are no errors or problems with the file.

2. To check the downloaded log file go to the **Log File** folder shortcut on the desktop and double click to open. Find the correct file and rename the file PondName.date.csv (e.g.: 2011.02.01.Pond.location.SerialNumber.csv). This will create a comma delimited text file that can be opened with Microsoft Excel. Open the file by double clicking on it and check it for completeness, errors or other problems. Log files should be moved out of the **Log File** folder or at the very least renamed to prevent them from being overwritten the next time data is downloaded.

### ***Programming with a Laptop Computer***

1. Once the data has been downloaded you can proceed to programming and calibration of the Datasonde. Select the **Operate Sonde** button on the main Hyrdas3 LT screen. If the instrument does not respond you may need to **Re-Scan for Sonde** until a connection is established again. Once a connection is established the **System** screen will appear.
2. On this screen you should check that the date and time are correct. If the time is not correct use the **Set clock to PC time** button. You can also turn the circulator and audio off or on, and adjust the security level.  
**Note: The security level must be at least 2 to be able to perform calibration.**
3. You can now proceed to the Online Monitoring Screen. Select the tab at the top of the screen. Press start and check the internal battery voltage. If the battery voltage is 10 or below you should replace the batteries before the instrument is redeployed. Refer to **Redeployment Procedures** for battery replacement. You can now press Stop and proceed to the with redeployment or log files. Select the **Log File** tab at the top of the screen and the following window should appear:
4. To check a log file select the file from the pull down window and review to make sure all the information is accurate.
5. To delete a log file select the **Disable** button at the bottom of the screen, and then select the **Delete** button. You will be prompted to make sure this is what you want to do.
6. To create a log file select the **Create** button at the bottom of the screen. You will be prompted to name the file. Be sure to not name it the same name as one of the other files. Then you will need to complete the following fields:

**Start Logging:** This should be the date when you want the instrument to begin logging.  
***The time needs to be at least 15 minutes in the future to allow time for the file to save.***

**Stop Logging:** This should be the date when you want the log file to stop logging. It is a good idea to set up the log file for a least 1 month or 1 week past when you are scheduled to check the equipment, in case there is a problem or delay in checking the instrument.

**Logging Interval:** This is the time interval at which you want the instrument to log. ***This should be set to 15 minutes.***

**Sensor Warmup:** This is the amount of time for the sensors to warm up. *This should be set to 2 minutes.*

**Circulator:** This is the amount of time that the circulator should run before the reading is taken. *This should be set to 2 minutes.*

**Parameters in Log File:** These are the parameters you want to be recorded in the log file. *Standard parameters to select are: Temp (C °), pH (Units), SpCond (mS/cm), Salinity (ppt), DO / LDO (mg/l), DO/LDO %, Internal Battery (volts). Turbidity (NTUs) is not standard but may be selected if required.*

Once the parameters and other options are selected you must select the **Save Settings** button in the top right corner. Then you must select the **Enable** button at the bottom of the screen. The program will show that the file has been saved and enabled by flashing a bar noting the time until start next to **Status**. If this does not appear you may need to create another log file, and be sure that you allow for 15 minutes into the future for it to begin logging. Creation of new log files should be recorded in the Calibration/Maintenance Notebook.

## Calibration with a Laptop Computer

1. Once the log file has been created and enabled you can redeploy the instrument or proceed to calibration. Select the **Calibration** tab at the top of the screen and the following window should appear:

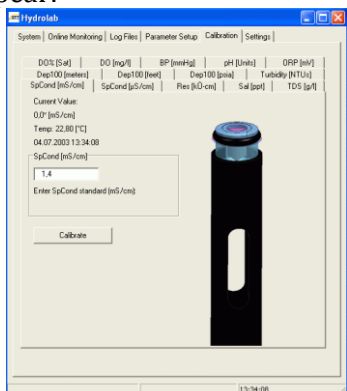

2. Select a sensor in this window and press the **F1** key. A window will be displayed, explaining the calibration procedure for this sensor in detail.
3. Under **Current Value**, the current value of the sensor you want to calibrate is displayed as well as the current temperature and the current time.
4. The standards (turbidity standard, pH standard, conductivity standard, and the distilled water) need to equilibrate to the pond temperature before the calibration - fill a bucket with pond water and let the standards rest in the water for several minutes. Before and in between calibrations, thoroughly rinse sensors and probes with distilled water. Before calibrating pH and conductivity, rinse sensors and probes with the standard. If the value of the standard changes with temperature, calibrate using the appropriate value. All calibrations and/or maintenance should be entered in the Calibration/Maintenance Notebook. Entries should include the date, serial number of the equipment, calibrations performed, outcome of calibrations, notes of problems or failed calibrations, notes of actions taken, any replacement of parts or maintenance, expiration dates and lot numbers

of all standards/parts/electrolyte solutions used, and the barometric pressure at the time of calibration.

- **Conductivity calibration:** Calibrate to 0 (in air) and to the supplied standard (47.6 (mS/cm) for low salinity ponds and 80 (mS/cm) for high salinity ponds). Make sure to submerge all sensors (with the exception of the turbidity sensor) with the standard. Record the pre-calibration reading for the standard. To calibrate, enter the standard value, click on the **Calibrate** button to perform the calibration. A message window then informs you if calibration was successful or not. \*Note: the conductivity calibration must be performed prior to DO calibration.
- **DO% saturation calibration:** Before calibration of DO%, make sure that the Circulator is turned off and the DO membrane/LDO cap are in good condition – replace if necessary. You can turn off the Circulator from the **System** window. Make sure to thoroughly rinse all sensors with tap water. Remove the calibration cup and gently dry the DO membrane with a Kim wipe, replace the calibration cup and fill it with tap water to just below the membrane / o-ring. Cover the calibration cup with the cap - setting the cap upside-down on top of the calibration cup, allowing a small amount of air to enter the cup. Read the supplied barometer in millibars (example: 772). Allow the Datasonde to equilibrate for 2 to 3 minutes. Make sure that the calibration cup is not in direct sunlight or in the presence of a heat or light source that could change the temperature in the calibration cup. To calibrate enter the value obtained from the barometer reading then click on the **Calibrate** button to perform the calibration. A message window then informs you if calibration was successful or not. After the calibration is complete, record the temperature and mg/L on the calibration log sheet.  
*If Calibration Failed!* appears, check to make sure the DO membrane is intact and free of perforations and/or bubbles. If the DO membrane appears to be OK, perform the calibration again. If unit is still failing calibration, turn it off and on and perform the calibration again. If *Calibration Failed!* appears again, change the DO membrane and perform the calibration again. If this does not correct the problem, call Hydrolab customer support number.
- **LDO% saturation calibration:** **Additional care should be taken to NOT expose the units with LDO sensors to direct sunlight. All calibrations of these units should take place in a shaded location.** Make sure to thoroughly rinse all sensors with tap water. Remove the calibration cup and gently dry the LDO cap with a lint-free microfiber type cloth (the same type used to clean computer screens). Replace the calibration cup and fill it with **air-saturated water** (see preparation on next page) to just below the top of the calibration cup (Image 1 ). Cover the calibration cup with the cap - setting the cap upside-down on top of the calibration cup (Image 2). Make sure that the calibration cup is not in direct sunlight or in the presence of a heat or light source that could change the temperature in the calibration cup. If needed, protect the calibration cup with a reflective shield. Read the supplied barometer in millibars (example: 772). Allow the Datasonde to equilibrate for 3 to 5 minutes. To calibrate enter the value, click on the **Calibrate** button to perform the calibration. A message window then informs you if calibration was successful or not. After the calibration is complete you should record the temperature and mg/L on the calibration log sheet.  
*If Calibration Failed!* appears, check to make sure the LDO cap is intact and free of scratches. If the LDO cap appears to be OK, perform the calibration again. If unit is still failing

calibration turn off and on and perform the calibration again. If *Calibration Failed!* appears again, changed the LDO cap and perform the calibration again. If this does not correct the problem call Hydrolab customer support number.

### Preparation of air-saturated water:

1. Take a 1-L bottle and fill it 50% with tap water (or a 1-gallon bottle with 500cc of tap water). Water should be allowed to equilibrate with atmospheric pressure approximately 12 hours before calibration.
2. Make sure the water in the bottle is close to temperature equilibrium with the calibration environment.
3. Seal the bottle and shake it vigorously for 40 seconds. The water is now ready for calibration.

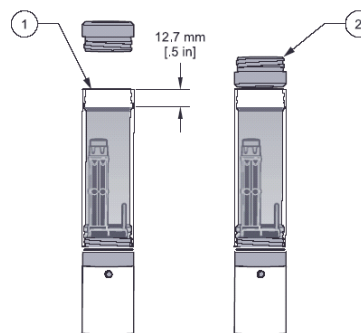

- pH calibration: Calibrate the pH using the 7 and 10 standards. Make sure to submerge all sensors (with the exception of the turbidity sensor) with the standard. pH should be compensated for temperature. Once the standard is in the calibration cup allow it to equilibrate. Record the pre-calibration reading for the standard and temperature, and consult the pH standard bottle for the temperature compensation that the unit should be calibrated too (example: pH 7.00 = 7.04 at 25°C, calibrated to 7.00). To calibrate enter the value, click on the **Calibrate** button to perform the calibration. A message window then informs you if calibration was successful or not. If *Calibration Failed!* appears, check to make sure the pH Teflon bridge is not discolored. If the Teflon bridge is discolored replace it using the maintenance kit. Discard the old pH electrolyte in the sensor and remove all old salt pellets. After discarding the old fluid and pellets, rinse the chamber twice with new pH electrolyte then refill the sensor with new electrolyte, and add two new salt pellets to the chamber. Perform the calibration again.
- Turbidity: Calibrate to 0 (using distilled water) and 100 NTU. Depending on standard used, it may need to be diluted first. For example, if using a 4000 NTU standard, you will need to use distilled water to dilute the standard to 100 NTU prior to calibration. Use a graduated cylinder to measure out **975ml of water and 25ml of standard**, this should be about 100 NTU. Turbidity can be performed using the calibration cup for Datasondes. To conserve standard (very pricey) fill the calibration cup to about ¼ full then turn datasonde upside down so the calibration cup is now at the bottom of the datasonde. The top ¼ of the turbidity sensor should be submerged in the standard, if not, add more standard. To calibrate successfully, make sure the standard is without bubbles and in the shade (blue paper towels can be wrapped around the cup to create a shaded environment). Prior to calibrating, it is a good idea to program the turbidity wiper to make one full revolution to ensure no air bubbles are trapped under the wiper, which may cause calibration failures. One full revolution should be completed for each standard used (low and high limits). To calibrate enter the value, click on the **Calibrate** button to perform the calibration. A message window then informs you if calibration was successful or not. If *Calibration Failed!* appears, check to make sure the cup is shaded well and perform the calibration again. If unit is still failing calibration, turn off and on and/or remix a new batch of standard and perform the calibration again.



- Temperature: Simply check the Datasonde thermometer against a standard thermometer.
5. Calibration can also be done with the Surveyor. Refer to the Minisonde calibration for procedure.
  6. Once the calibration is complete you can exit from the Hyras3 LT program and disconnect the Datasonde from the laptop. Replace the calibration cup with the sensor guard and place the Datasonde back in the bucket with the Minisonde. Connect the communication cable for the Datasonde back to the Surveyor and turn on circulator (**Setup/Cal, Setup, Sonde**, arrow to **Circulator**, select 1 to turn it on). Turn on the Minisonde in the bucket also. Once both units are on, wait 2 minutes and take a final simultaneous reading with both the Datasonde and Minisonde, and record on data sheet (“**post-cal**” reading). The Minisonde can now be put away, refer to Minisonde storage procedure. Make sure to turn off the Datasonde circulator (**Setup/Cal, Setup, Sonde**, arrow to **Circulator**, select 0 to turn it off). The Datasonde is now ready for (Re-)Deployment.

### ***Deployment and/or Redeployment Procedure***

1. Disconnect the communication cable and replace the dummy plug to protect the connection prongs. Make sure that all the air is released from the plug and that it is seated firmly over the connection prongs.
2. If the batteries need to be replaced unscrew the screw cap and carefully lift the cap to the battery compartment – a screwdriver can be used if the seal is tight. Make sure the battery compartments are clean and dry. Clean and re-grease the O-ring on the cap and replace if bad. Change out batteries paying special attention to (+) and (-). Then put the insulating grease on the end cap before putting it on the instrument, pressing down firmly until it is seated and tighten the screw cap.
3. If the Datasonde is in a pond with algal and barnacle growth place a copper mesh sleeve over the sensor guard and a nylon stocking over the entire instrument to keep it in place. Nylon stocking should also be used in ponds algae to prevent it from tangling around the circulator and self-cleaning brush causing them to stop working.
4. Reattach the security device and lock the padlock.
5. Reattach the Datasonde to the PVC holder and tighten the hose clamps to keep it in place. Lower the instrument into the water and check to make sure that it is submerged and moving freely.

### ***Storage***

1. When a Datasonde is pulled from the field for storage or repair, the log file should be disabled and deleted unless this is the reason for the repair. In this case the file should be disabled so that the problem can be diagnosed.
2. The Datasonde should be well cleaned and stored with the calibration cup partially filled with TAP water. The Surveyor4 battery will need to be recharged before use in the field.

### 13.7 Discrete Water Quality Standard Operating Procedures

USGS Western Ecological Research Station SFBE

*Suggested citation: US Geological Survey. 2011. Water quality, discrete standard operating procedures. Unpublished protocols. USGS, Western Ecological Research Center, San Francisco Bay Estuary Field Station, Vallejo, CA.*

*Disclaimer: Any use of trade, product, or firm names in this publication is for descriptive purposes only and does not imply endorsement by the U.S. government.*

#### **Purpose/Objective:**

Water quality controls the distribution of vegetation, benthic invertebrates, and fishes. Discrete water quality sampling can provide a “snapshot” of water quality parameters and is a useful, mobile tool for collecting water quality parameters at fish and invertebrate sampling stations.

#### **Equipment:**

Handheld water quality meter (YSI Professional Plus recommended)

YSI Professional Plus User Manual

Tap water

Datasheet & Pencils

#### **Methods:**

1. Turn on YSI approximately 5 - 15 minutes before use to let the unit warm up. This helps with the DO reading.
2. Calibrate YSI for dissolved oxygen using the “DO% in Water Saturated Air” method outlined in User Manual.
3. Take two water quality readings. One just below the surface of the water, and the second just above the sediment surface. If the water is too shallow (i.e. < 1 m), take a reading in the middle of the water column. Immerse the probe completely and give it a quick shake to release any air bubbles. Allow the temperature readings to stabilize. Next, stir the probe in the water to overcome the stirring dependence of the dissolved oxygen sensor. Note: if placing the probe into a stream or fast flowing water, it is best to place it perpendicular to the flow and NOT facing into the flow.
4. Record water quality parameters on “Water Quality” datasheet (see below).
5. Rinse probe and wipe salt water off of YSI at end of day. Store and transport YSI in Pelican case.

**Water Quality**

**Dissolved Oxygen Calibration**

Date\_\_\_\_\_ Time\_\_\_\_\_ Observers\_\_\_\_\_ DO% Before\_\_\_\_\_ DO% After\_\_\_\_\_

Location:

Time:

Circle one: surface/bottom/middle

Temp °C	
Barometric inHg	
DO%	
DO mg/L	
Spec. Cond μS	
Cond μS	
Salinity ppt	

Comments:

Location:

Time:

Circle one: surface/bottom/middle

Temp °C	
Barometric inHg	
DO%	
DO mg/L	
Spec. Cond μS	
Cond μS	
Salinity ppt	

Comments:

Location:

Time:

Circle one: surface/bottom/middle

Temp °C	
Barometric inHg	
DO%	
DO mg/L	
Spec. Cond μS	
Cond μS	
Salinity ppt	

Comments:

Location:

Time:

Circle one: surface/bottom/middle

Temp °C	
Barometric inHg	
DO%	
DO mg/L	
Spec. Cond μS	
Cond μS	
Salinity ppt	

Comments:

## 13.8 Sediment Pin Standard Operating Procedures

USGS Western Ecological Research Station SFBE

### **Purpose/Objective:**

As part of post-restoration monitoring, we measure sediment pins semiannually. We use sediment pins to track sediment changes at discreet locations over time. This method can be used along with bathymetry and terrestrial LiDAR, which collect elevation data at many more points. Sediment pin data can be used to provide a 'spot check' on these larger and more complicated data sets.

### **Equipment:**

Study area map showing spatial distribution of sediment pins	Rite-in-the-rain notebook for site visited
List of sediment pin UTM coordinates	Paint pens to rewrite numbers on sed pins
Sediment measuring pole (flat bottom)	Pen/pencil
	Kayak or boat (if needed)

### **Methods:**

#### ***Construction and Placement***

Sediment pins are constructed from 2-inch gray, UV-resistant PVC pipe. The pipe is cut to an appropriate length for the anticipated water depth and substrate conditions. The pipe must be visible above the water line at high tide if you plan to access via boat. Sediment pins that will be accessed during low tide on the marsh plain may be shorter to create a lower profile. Pipes are driven into the ground at least 3 feet with a pipe/post driver or auger. If necessary, two pieces of PVC may be connected using couplers to increase sediment pin length. After installation, label the sediment pin with its designated number using a paint pen. Measure each sediment pin after placement (see Measurement).

PVC pipes should be placed prior to dike removal. Sediment pins will be placed in conjunction with channel cross sections and permanent vegetation transects at 5 and 40 meters along the vegetation transect. Spatial distribution of sediment pins should be representative of the topography, expected/planned environmental development, and water flow dynamics of a project site. Do not place the pins in channels or areas with anticipated strong currents that may cause artificial scour around the pin. We measure the distance from the top of the sediment pin to the sediment semiannually.

#### ***Pin Elevation***

Upon placement, sediment pins are surveyed for accurate elevation of the pin height. Future "as built" surveys of topography at project sites should include re-surveying of sediment pin tops (or every 2-3 years). Comparison of pin elevations over time will allow determination of vertical pin movement and accurate representation of sediment loss or gain. In the absence of "as built" surveys conducted by landholders, staff should use professionally surveyed benchmarks to survey staff gauges and sediment pins using differential leveling and 'slack tide' methods described in Zedler (2000).

#### ***Measurement***

Sediment accumulation is monitored through time by measuring the distance from the top of the sediment pin to the surface of the sediment below. Four measurements are taken at each pin (e.g., north, east, south, & west) to derive an average estimate of sediment gain or loss.

The measuring device should be set gently on top of the sediment (almost hovering), not pushed down or allowed to settle into the mud. Take note of any scour holes around sediment pin and take additional readings outside scour holes if necessary. If using more than one measuring pole, make sure that they are the same measurements. If the poles do not have the same measurements, note which one you are using and adjust your numbers based on how off it is from real measurements.

Sediment accumulation or loss is determined by comparing measurements at sediment pins through time. For example, reading 1 shows the distance from the top of the pin down to the sediment as 63 cm. The second reading shows the distance as 61 cm revealing sediment accumulation of 2 cm (Figure 1). Data to record: project, date, observer, sedpin #, UTM coordinates, sediment measurements. Data are entered into each projects database. When entering data into the database, keep the UTM coordinates constant for each pin. Do not use variable UTM's recorded in the field (these are only used to validate the identification of a specific pin). It is also helpful to take note of ideal boating conditions (i.e. best time/tide to avoid mudflats or to capture sediment pins barely above water level).

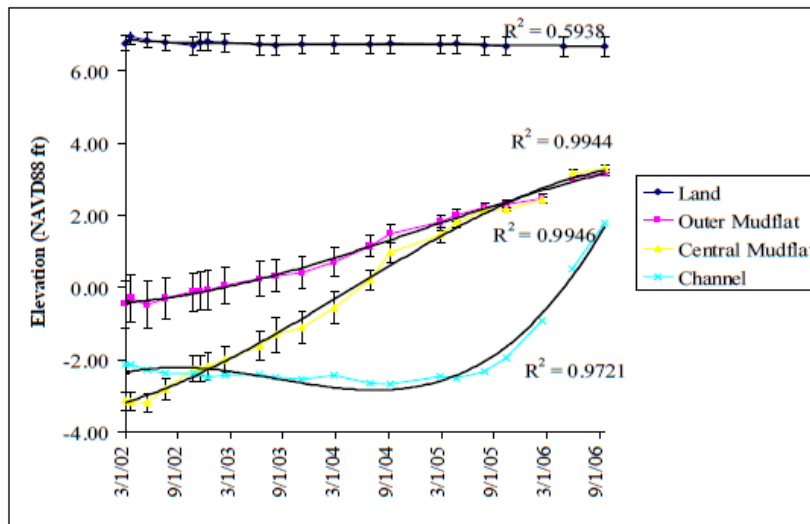

**Figure 2.** Example graphical representation of sediment pin data from Tubbs Setback Restoration Project, CA (Woo et al 2007). Sediment elevation (NAVD88 ft) at 24 sediment pin locations from March 2002 to September 2006. After 3.5 years, the central and outer mudflat areas reached an intersection point despite an almost 3 ft difference in average initial elevation. The channel has shown an almost 3 ft increase in elevation since 2005.

### Sediment Pin Datasheet

Observers \_\_\_\_\_

Date \_\_\_\_\_

Site	Unit (i.e. 2N)	Pin No.	Height (N) (cm)	Height (E) (cm)	Height (S) (cm)	Height (W) (cm)	Notes



## 13.9 Benthic Invertebrate Standard Operating Procedures

USGS Western Ecological Research Station SFBE

*Sieving methods were modified from: US Geological Survey. 2010. Invertebrate lab manual. Unpublished benthic invertebrate sieving and sorting protocols. USGS, Western Ecological Research Center, San Francisco Bay Estuary Field Station, Vallejo, CA.*

*Suggested citation: US Geological Survey. 2011. Benthic invertebrate standard operating procedures. Unpublished protocols. USGS, Western Ecological Research Center, San Francisco Bay Estuary Field Station, Vallejo, CA.*

*Disclaimer: Any use of trade, product, or firm names in this publication is for descriptive purposes only and does not imply endorsement by the U.S. government.*

### Purpose/Objective:

Invertebrates convert decomposing marsh plants and detritus into biomass available to fish and avian communities at higher trophic levels. As such, invertebrates are useful early monitoring indicators of the success of the estuary restoration project. All surveys conducted will be proximal to a monitoring station.

### Equipment:

#### Collection

- Sediment corer (a.k.a. Clam gun)
- Ziploc bags (1gallon) bring extras
- GPS
- Aerial Photo with core locations
- Core scraper for straight edge
- Waders
- Backpacks
- Flexible spatula
- 5 gallon buckets (3-4)
- YSI
- Sample Data Tracking Sheet
- Mud shoes (if needed)
- Cooler (to keeps cores cold)

#### Sieving

- Sample Data Tracking Sheet
- Number 35 (0.5 mm) sieve
- Pencils, black thick sharpie
- Labels
- 16 oz. Nalgene squirt bottles
- 4 or 8 oz polystyrene jars, lids
- Dissecting forceps, spatula
- Bottomless bucket (of same diameter as sieve)
- Cooler (to keeps cores cold)
- 70% Ethyl alcohol with Rose
- Bengal dye (Be careful-read MSDS)
- Hose

### Methods:

#### Collection

1. Inverts are collected at low tide when the channel bottom is exposed; the tide level at which this occurs will vary from site to site. Ten cm diameter and 10 cm deep sediment cores will be taken with a wetland sediment corer. After inserting corer 10 cm, place a finger on the hole just underneath the handle to create suction. Lift core and dump into **labeled** plastic bag (label with site, date, core#, on the outside and with a Rite in the Rain label on the inside). *Note: Due to muddy conditions, it is better to label bags before going out into the field.. Let air out of bag and seal securely. Place in bucket or backpack. (Try to limit inverts from direct sunlight and heat for long durations. If needed, take to truck and place in shade.)*
2. The number of replicates will be determined by study design. An additional core will be taken to analyze for sediment characteristics (particle size, organic content, nutrients, etc.).

3. Use handheld YSI to measure water quality (temperature, salinity, dissolved oxygen, and conductivity) readings halfway along the sampling reach.

### **Sieving**

Samples with large amounts of clay and silt may need to be re-rinsed and re-sieved prior to sorting, in order to help break up large lumps of clay and ensure adequate preservation of specimens. Sodium hexametaphosphate ((NaPO<sub>3</sub>)<sub>6</sub>) can be used to help disperse large clumps of clay and fine silt (cf. Bamber 1982). This is unlikely for mudflat cores.

1. If the sample contains a lot of silt or clay, add a small amount (approximately 0.1 g) of sodium hexametaphosphate ((NaPO<sub>3</sub>)<sub>6</sub>) to samples, gently shake and allow to sit for at least 12 hours.
2. Gather a 0.5 mm sieve, the data sheet, and take your samples to a hose or utility sink. If sieving many samples, keep core samples in a cooler or fridge until sieving.
3. Pick a sample to process and examine the contents. Make sure any samples needed for sediment analysis are taken before sieving. Start a new datasheet for each sample location and record the following:

At top of data sheet:

Project name, location within project, date of collection, number of cores, and names of collectors

For each sample:

Sample ID, initials of seiver, and date of sieving

4. Place bottomless bucket into sieve to prevent loss of sample during rinsing. Pour contents into sieve, rinsing gently under water to ensure that the entire sample is retained (do not push anything through sieve). Rinse the sample until as much soil as possible is removed, especially clay. Discard rocks or other large pieces of material after visually checking for organisms.
6. Put the rinsed material into an appropriately size jar (4 or 8 oz) and make sure jar is labeled on both the side and lid, and a rite-in-the-rain label is placed inside the jar. Add solution of rose Bengal and ethyl alcohol until the material is just covered.

### **How to Make Rose Bengal 70% Ethanol Solution**

3 L of 95% Ethanol=2850 mL Ethanol

2850 mL Ethanol/X =70% Ethanol Solution

2850 mL Ethanol/0.7=X

X=4071 mL

4071 mL-3000 mL=1071 mL

So, add:

**-3000 mL of 95% Ethanol**

**-1071 mL DI H<sub>2</sub>O**

**-Small spatula of Rose Bengal**

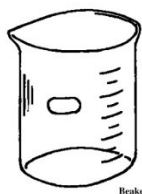

### 13.10 Terrestrial Invertebrates Standard Operating Procedures

USGS Western Ecological Research Station SFBE & Nisqually Indian Tribe

*Procedures modified from: Simenstad, C.A., A.J. Wick, J.R. Cordell, R.M. Thom, and G.D. Williams, 2001. Decadal development of a created slough in the Chehalis River estuary: year 2000 results. Report to U.S. Army Corps of Engineers, Seattle District.*

*Suggested citation: US Geological Survey and Nisqually Indian Tribe. 2011. Terrestrial invertebrates, fall-out trap standard operating procedures. Unpublished protocols. USGS, Western Ecological Research Center, San Francisco Bay Estuary Field Station, Vallejo, CA. Nisqually Indian Tribe Natural Resources Office, Olympia, WA.*

*Disclaimer: Any use of trade, product, or firm names in this publication is for descriptive purposes only and does not imply endorsement by the U.S. government or Nisqually Indian Tribe.*

**Purpose/Objective:**

To assess capacity of the restoration to produce prey resources for juvenile Chinook salmon, we will sample insects that fall into the water from the aerial environment using fall out traps. This sampling is paired with fyke net surveys for juvenile Chinook. These traps measure the direct input of invertebrates from the marsh to the aquatic system by capturing insects that fall or settle onto the surface of the water (Gray et al 2002). Three replicate traps will be deployed monthly between March and August at each intensive fish sampling site during the low tide and allowed to float with the tide. The traps will be left to sample for 48 hours over an entire tidal cycle.

**Equipment:**

**Installation**

10ft PVC poles or metal conduit (4 per trap)  
 1 Trap/bin ((0.25 m2, 55-cm x 38-cm rectangular plastic basins)  
 Rubber mallet or post pounder  
 GPS

**Setting up**

3-6 Traps/bins (0.25 m2, 55-cm x 38-cm rectangular plastic basins)  
 String/Fishing line  
 Soap  
 Clock  
 #120 sieve

Bucket

**Collecting**

6 Containers with lids  
 Ethanol  
 #120 sieve  
 Tweezers  
 Spoon  
 Clock  
 Datasheet  
 Bucket  
 Backpack

**Methods:**

**Installation**

Select trapping locations along channel edge at each fyke netting sampling station. Fall-out traps should be placed upstream of fyke net and far enough away that they are not trampled during fyke netting surveys. Three to six fall-out traps should be installed per fyke net location. For habitat type comparisons, place three replicates in one habitat type (i.e. *Carex lyngbyei*) and another three in a different habitat type (i.e. *Distichlis spicata*). Replicates should be placed at least 1 meter from each other. At each fall-out trap location, pound in PVC or conduit in a diamond-shape pattern (Figure 1) using the rectangular plastic trap as your guide. Record the UTM coordinates of each trap. Drill a small hole into the edge of each plastic trap so that it can be tied to the poles.

### **Setting up**

Put traps between the 4 poles. Pour soap in the bottom; not too much as it will clog the sieve when collecting, but just enough to break the water surface. Pour water through the sieve into the trap; only need a few inches. Swirl water around to mix with soap. Record time for each trap set up. Tie at least one end of the trap to the poles.

### **Collecting**

Ideally, each trap would be collected 48 hours after it has been set, though collections can occur within 46 – 50 hours of set time. Detach trap and lift away from poles. Have partner hold sieve or if confident place sieve on ground and pour. Put invertebrates in labeled container (label with site, date, and trap# on the outside and with a Rite in the Rain label on the inside). *Note: Due to muddy conditions, it is better to label bags before going out into the field.* Place debris in as well as it may be hiding invertebrates. Pouring ethanol in beforehand can help to eliminate soap bubbles. Pool a little water in the corner of the sieve and pour invertebrates in, instead of using a tweezer for each individual. Make sure there is more ethanol than water in the container (about 70%). Add rose-bengal to sample when out of the field. Place containers in bucket or backpacks. Store samples in a cool, dark location.



**Figure 1.** Fall-out trap on bank of Animal Slough, Nisqually, WA.

## 13.11 Pelagic Invertebrates Standard Operating Procedures

USGS Western Ecological Research Station SFBE & Nisqually Indian Tribe

*Suggested citation: US Geological Survey and Nisqually Indian Tribe. 2011. Pelagic invertebrates standard operating procedures. Unpublished protocols. USGS, Western Ecological Research Center, San Francisco Bay Estuary Field Station, Vallejo, CA. Nisqually Indian Tribe Natural Resources Office, Olympia, WA.*

*Disclaimer: Any use of trade, product, or firm names in this publication is for descriptive purposes only and does not imply endorsement by the U.S. government or Nisqually Indian Tribe.*

### **Purpose/Objective:**

Neuston net tows are used to quantify the availability of prey organisms within the water column for fish predators. This sampling is paired with Fyke net surveys for fish.

### **Equipment:**

neuston net with attached cup (153 $\mu$ m)  
1 container with lid  
Ethanol  
Tweezers  
Spoon  
Datasheet

### **Methods:**

The samples are collected by dragging a neuston net along the surface of the water column within the slough or channel. Take care that the entire mouth of the net is within the water column. Each month from March - August, collect three samples throughout an outgoing tide at each fish sampling location and pool contents to have one sample per site. Specimens will be sieved with a 0.5 mm screen, preserved in a 70% ethanol/rose-bengal solution. Abundances from samples will be standardized to area and reported as average density of invertebrates per volume of water.

## 13.12 Bird Area Survey Standard Operating Procedures

USGS Western Ecological Research Station SFBE

*Suggested citation: US Geological Survey. 2011. Bird area survey standard operating procedures. Unpublished protocols. USGS, Western Ecological Research Center, San Francisco Bay Estuary Field Station, Vallejo, CA.*

*Disclaimer: Any use of trade, product, or firm names in this publication is for descriptive purposes only and does not imply endorsement by the U.S. government.*

### **Purpose/Objective:**

Waterbirds feed on a variety of resources produced in a healthy estuary, including benthic and terrestrial invertebrates, seeds of marsh vegetation, and the stems, leaves and seeds of aquatic vegetation. As such, birds are useful monitoring indicators of the success of the estuary restoration project.

### **Equipment:**

binoculars	site map showing UTM grid
spotting scope	watch/timer
data forms/notebook, pencil	GPS (optional)

### **Methods:**

Surveys should be conducted during high and low tides. High tide surveys are designed to capture the presence of waterfowl and dabbling ducks, and low tide surveys target shorebirds. Near each monitoring station, the site will be partitioned into 100-250 m UTM grids overlaid on a site map using ArcGIS so that an observer can reference the location in which birds are detected. Data recorded during area surveys includes: project, date, start time, end time, tide, weather, area/grid, species, numbers of each species, environment of sightings, and bird behavior. Area surveys are a snapshot of bird use in a particular area. As such, birds are identified and enumerated quickly while moving throughout the study area. Good bird surveys are a balance of maintaining scientific accuracy while also working efficiently.

Record all birds within defined areas (also include individuals that have originated or ended their flight within the study area). Only count birds in the study area. Birds observed on levees should be recorded as such. Record each species using a four-letter code composed of either the first four letters of the common name or the first two of each if the common name consists of two words. (e.g. RTHA=red-tailed hawk, RPHE=ring-necked pheasant). When in doubt, be conservative. If you are not sure of the species of a bird, record the taxonomic group you are certain of. For example, record “dabbling duck” if you don’t know the species, or “duck” if you don’t know the species or foraging guild.

Record the environment and behavior of each bird or group of birds observed. Codes for weather, habitat and behavior are:

#### ***Weather:***

wind: (0 = 0-5mph; 1 = >5-15 mph; 2 = >15mph)

sky: (% sky cover)

precip: (0 = no rain, 1 = mist/drizzle, 2 = light rain, 3 = moderate to heavy rain)



### ***Habitat/Environment:***

MF = mudflat (exposed during low tide)

MP = marsh plain

BD = bare dirt

UP = upland

LV = levee or dike

OW = open water

SH = shallow water

PO = pond or pooled water

AE = aerial

CW = in channel water

SC = dry or seasonal channel

RV-CK = river or creek

OP = outside project (still in grid)

UNK = unknown (note if on manmade structure)

### ***Behavior\*:***

FO = foraging

RO = roosting

PR = preening

FL = flyover

SW = swimming

CA = calling

PE = perched

AL= alert

UN = unknown

CD = courtship display

CN = carrying nest material

CF = carrying food

AG = aggression

\*This list is by no means exhaustive. If you observe other behaviors worth identifying, please state clearly on the data sheet for later inclusion into methods.

### **Data Analysis:**

Summarize data from each area: species richness, total bird abundance. Add species to master list. Evaluate differences in these parameters across areas, high vs. low tides within and among areas, across seasons, and through time since project inception. As data accumulates, programs should be written in SAS to quickly produce desired statistics.

# TNC PSB Restoration Monitoring Plan

Page \_\_\_\_ / \_\_\_\_.

**Site:** \_\_\_\_\_ **Area Bird Survey Form** **Date:** \_\_\_\_\_ **Tide:** \_\_\_\_\_

Observers	Start Tide/End Tide /	Start Time/End Time /	Temp	Wind (0-5)	%Sky cover	Precipitation
-----------	--------------------------	--------------------------	------	------------	------------	---------------

**Habitat/Environment:** MF = mudflat (exposed during low tide), MP = marsh plain, BD = bare dirt, OW = open water, SH = shallow water, UL = upland, LV = levee or dike PO = pond or pooled water, AE = aerial, CE = channel edge, CW = in channel water, SC = dry or seasonal channel, RV-CK = river or creek, OP = outside project (still in grid), UNK = unknown, note if on manmade structure

**Behavior:** FO = foraging, RO = roosting, CA = calling, FL = flyover, SW = swimming, PR = preening, PE = perched, AL = alert, UN = unknown, CD = courtship display, CN = carrying nest material, CF = carrying food, AG = aggressive display

Grid	Species	Number	Habitat/Environment	Behavior	Notes/Time
			MF MP BD OW SH UL LV PO AE CE CW SC RV- CK OP UNK	FO RO CA FL SW PR PE AL UN CD CN CF AG	
			MF MP BD OW SH UL LV PO AE CE CW SC RV- CK OP UNK	FO RO CA FL SW PR PE AL UN CD CN CF AG	
			MF MP BD OW SH UL LV PO AE CE CW SC RV- CK OP UNK	FO RO CA FL SW PR PE AL UN CD CN CF AG	
			MF MP BD OW SH UL LV PO AE CE CW SC RV- CK OP UNK	FO RO CA FL SW PR PE AL UN CD CN CF AG	
			MF MP BD OW SH UL LV PO AE CE CW SC RV- CK OP UNK	FO RO CA FL SW PR PE AL UN CD CN CF AG	
			MF MP BD OW SH UL LV PO AE CE CW SC RV- CK OP UNK	FO RO CA FL SW PR PE AL UN CD CN CF AG	
			MF MP BD OW SH UL LV PO AE CE CW SC RV- CK OP UNK	FO RO CA FL SW PR PE AL UN CD CN CF AG	
			MF MP BD OW SH UL LV PO AE CE CW SC RV- CK OP UNK	FO RO CA FL SW PR PE AL UN CD CN CF AG	
			MF MP BD OW SH UL LV PO AE CE CW SC RV- CK OP UNK	FO RO CA FL SW PR PE AL UN CD CN CF AG	
			MF MP BD OW SH UL LV PO AE CE CW SC RV- CK OP UNK	FO RO CA FL SW PR PE AL UN CD CN CF AG	
			MF MP BD OW SH UL LV PO AE CE CW SC RV- CK OP UNK	FO RO CA FL SW PR PE AL UN CD CN CF AG	
			MF MP BD OW SH UL LV PO AE CE CW SC RV- CK OP UNK	FO RO CA FL SW PR PE AL UN CD CN CF AG	
			MF MP BD OW SH UL LV PO AE CE CW SC RV- CK OP UNK	FO RO CA FL SW PR PE AL UN CD CN CF AG	
			MF MP BD OW SH UL LV PO AE CE CW SC RV- CK OP UNK	FO RO CA FL SW PR PE AL UN CD CN CF AG	

## 13.13 Variable Circular Plot Bird Survey Standard Operating Procedures

USGS Western Ecological Research Station SFBE

*Modified from: Conway, C. J. 2008. Standardized North American Marsh Bird Monitoring Protocols. Wildlife Research Report #2008-01. U.S. Geological Survey, Arizona Cooperative Fish and Wildlife Research Unit, Tucson, AZ.*

*Suggested citation: US Geological Survey. 2011. Variable circular plot bird survey standard operating procedures. Unpublished protocols. USGS, Western Ecological Research Center, San Francisco Bay Estuary Field Station, Vallejo, CA.*

*Disclaimer: Any use of trade, product, or firm names in this publication is for descriptive purposes only and does not imply endorsement by the U.S. government.*

### **Purpose/Objective:**

Variable circle plot surveys should be conducted monthly between April and June to encompass the breeding season for song birds and the pre-breeding season for marsh birds.

### **Equipment:**

binoculars and/or spotting scope  
data forms and pencils  
GPS  
site map showing sampling points with coordinates  
watch/timer  
wind/temperature meter

### **Methods:**

Variable circular plot (VCP) surveys are conducted just prior to sunrise to 2-2 ½ hours following sunrise. VCP surveys consisted of an initial 2-minute settling period followed by 8 minutes of data collection whereby all birds seen or heard within 150-m are recorded. Data recorded during this period consists of: Date, start and end time, observer, point/grid number, UTM, weather (wind speed, %cloud cover, temperature), species, number and distance to detected individuals by species, habitat, and behavior.

**Weather:** wind (0 = 0-5mph; 1 = >5-15 mph; >15mph)  
sky (% sky cover)  
precip (0 = no rain, 1 = mist/drizzle, 2 = light rain, 3 = moderate to heavy rain)

**Habitat:** MF = mudflat (exposed during low tide), MP = marsh plain, BD = bare dirt, OW = open water, SH = shallow water, UL = upland, LV = levee or dike PO = pond or pooled water, AE = aerial, CE = channel edge, CW = in channel water, SC = dry or seasonal channel, RV-CK = river or creek, OP = outside project (still in grid), UNK = unknown, note if on manmade structure

**Behavior:** FO = foraging, RO = roosting, CA = calling, SO = song, FL = flyover, SW = swimming, PR = preening, PE = perched, AL = alert, CD = courtship display, CN = carrying nest material, CF = carrying food, AG = aggressive display, UN = unknown, SI = just sighted

Species are recorded using standard North American 4-letter bird codes. Check for updated versions at least once per year. Individual birds are recorded up to a distance of 150-m. If

you are unable to make a positive identification, record family, group, etc. (ex. SPAR=sparrow, RAPT=raptor, shorebird = SHOR, swallow = SWAL). Identify those individuals that are flyovers as zero distance. If individuals are flying over but appear to be using the area (e.g., aerial foraging), please note this on the data form. Note juveniles on the data sheet when seen or heard.

### ***Data Analysis***

Seasonal estimates of bird density by species should be calculated using program DISTANCE when sample size allows. If numbers of certain species are inadequate to produce density estimates, mean number of birds per point should be reported. Density (#/ha) estimates will be examined among points within and across sampling periods. Density estimates are based on the area of a circle with radius  $r$ . The selection of  $r$  should be determined by plotting the number of birds observed by distance bands (#10-m). The maximum radius of the circle should be at the distance where a noticeable decline in detections occurs. Species richness should also be extracted from the data (species by point, season, year, master project list). Using the spatial capabilities of GIS, examinations of sensitive species locations/densities in relation to vegetation, hydrological, and other data layers should also be examined.

**Variable Circular Plot Bird Survey Datasheet** Pg. \_\_\_\_\_ of \_\_\_\_\_

--	--	--	--	--	--	--	--

Station

--	--

Month

--	--

Day

--	--	--	--	--

Year

--	--

Visit

Observers

**Habitat/Environment:** MF = mudflat (exposed during low tide), MP = marsh plain, BD = bare dirt, OW = open water, SH = shallow water, UL = upland, LV = levee or dike PO = pond or pooled water, AE = aerial, CE = channel edge, CW = in channel water, SC = dry or seasonal channel, RV-CK = river or creek, OP = outside project (still in grid), UNK = unknown, note if on manmade structure

**Behavior:** FO = foraging, RO = roosting, CA = calling, SO = Song, FL = flyover, SW = swimming, PR = preening, PE = perched, AL = alert, CD = courtship display, CN = carrying nest material, CF = carrying food, AG = aggressive display, UN = unknown, SI = just sighted

Point # i.e. MN, SM, FS	Time	Species	S/C/V Song/Call/ Visual	0-25	25-50	50-100	100-150	Habitat	Behavior	Notes

Weather Information: Please estimate temperature, cloud cover (% of sky covered by clouds), and approximate wind speed.

\_\_\_\_\_ ° F or C (circle one)      \_\_\_\_\_ %      \_\_\_\_\_ mph, knots, or kmph (circle one)

Temperature      Cloud Cover      Wind Speed

ENTERED \_\_\_\_\_ PROOFED \_\_\_\_\_

### 13.14 Habitat Mapping and Characterization

The Nature Conservancy

*Suggested citation: Heatwole, D. in Habitat mapping and characterization in Port Susan Bay: Summary of 2004-2005 monitoring. The Nature Conservancy. Seattle, WA*

*Disclaimer: Any use of trade, product, or firm names in this publication is for descriptive purposes only and does not imply endorsement by the U.S. government.*

#### **Purpose/Objective**

We mapped intertidal habitats across 2,160 ha of the existing Stillaguamish estuary in PSB. Using georeferenced infrared aerial photographs from summer 2003, we used ArcGIS to manually digitize approximate boundaries for six estuarine habitats: backshore (BS), high and low elevation emergent wetlands (HE and LE), vegetated and unvegetated tideflats (VT and UT), and non-native eelgrass (EG). In addition, we mapped diked wetlands (DW) and uplands (DU) within an adjacent 60-ha parcel owned by The Nature Conservancy.

Habitats were defined by apparent differences in intertidal elevation as well as vegetation density and composition. BS was infrequently inundated by tides and positioned behind a wrack line of large woody debris (LWD). Emergent wetlands occurred seaward of the LWD wrack line and supported emergent vegetation at  $\geq 25\%$  cover. HE was generally characterized by *Agrostis* spp. (bentgrass), *Juncus balticus* (Baltic rush), or *Carex lyngbyei* (Lyngby's sedge), and LE by *Scirpus americanus* (American bulrush) or *Scirpus maritimus* (maritime bulrush). Seaward of the wetlands were tideflats: VT supported emergent vegetation at  $< 25\%$  cover, and UT contained no emergent vegetation. EG occurred within the otherwise unvegetated tideflats and was characterized by  $\geq 25\%$  cover of *Zostera japonica* (Japanese eelgrass). Within the diked property, a wetland has recently developed in response to reduced pumping of rain and groundwater. We distinguished the wetland from upland by the presence of emergent estuarine species, ponded water, or decaying terrestrial grasses.

Habitats were groundtruthed at 223 stratified random locations throughout the estuary during 27 July–4 August 2004. The allocation of points among habitats was determined by conducting a sample size power analysis on vegetation species densities from 79 pilot points. For each habitat, we calculated the number of additional sampling points necessary to detect a 50% difference in densities of common plant species with 80% power and 10% Type I error rate. This number was then modified slightly for some habitats, based on feasibility and budgetary constraints. For the 223 groundtruthed points, 11 were allocated to BS, 44 to HE, 47 to LE, 29 to VT, 35 to UT, 22 to EG, 17 to DW, and 18 to DU. Sampling point coordinates were generated using Hawth's Analysis Tools for ArcGIS. We used a Trimble Pathfinder Pro XR global positioning system (GPS) to initially locate sampling points in the field. We marked sampling points with PVC pipe and recorded the observed habitat at each location.

In July 2005, we revisited 98 of the original 224 sampling points and added 10 new points to areas needing further map refinement. Overall, 23 points were assigned to HE, 24 to LE, 21 to VT, 12 to UT, 13 to EG, 10 to DW, and 5 to DU.



## Methods

### Habitat Characterization

Physical and biological characteristics of PSB's estuarine habitats were documented in two phases at the stratified random sampling points. Porewater salinity and substrate class were recorded during 27 July–4 August 2004 and 11–17 July 2005.<sup>1</sup> We also measured surface elevations and collected benthic invertebrate samples during this period in 2005. Vegetation, tidal channels, and LWD were characterized at each point during 22 June–8 September 2004 and 28 June–18 August 2005. The standard plot design for 2004 differed slightly from 2005 (Figure 1), including a square (vs. circular) vegetation plot, five (vs. four) 500-cm<sup>2</sup> vegetation subsamples, and four (vs. three) 50-m transects for tidal channels, LWD, and non-native plant species.

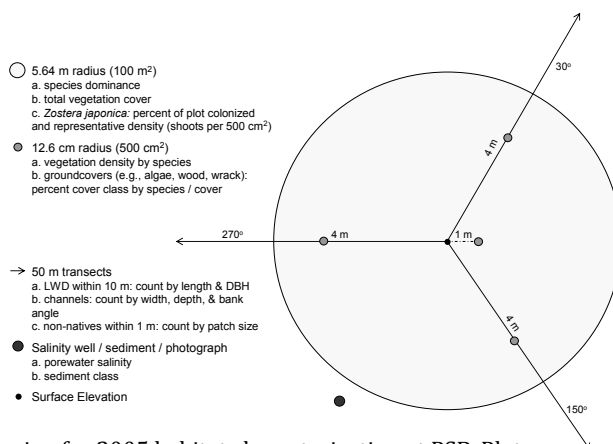

**Figure 1.** Plot design for 2005 habitat characterization at PSB. Plots were established at each stratified random sampling point.

Physical attributes were measured at each point to characterize effects of riverine and marine processes throughout the estuary, in terms of topography, salinity, substrate type, and LWD distribution. We used a Leica GPS1200 surveying system to record horizontal coordinates and surface elevations at the 2005 sampling points. A base station was established each day over one of two existing elevation monuments, located within 4 km of points to be visited that day. Porewater was accessed in temporary wells (dug with a hand auger), and salinity was gauged using a digital salinity-conductivity-temperature instrument. We qualitatively classified surface substrates using the general descriptions provided by McBride et al. (2005). Tidal channels and LWD were tallied by size class along three 50-m transects originating at the plot center and oriented at 30, 150, and 270° from north. We counted intersecting tidal channels according to width (<0.5, 0.5–2, 2–10, and >10 m), depth (<0.2, 0.2–0.5, 0.5–2, and >2 m), and bank angles (<5, 5–30, 30–75, 75–90, and >90° from horizontal) at the intersection point. We counted LWD within 10 m of each transect by length (5–15, 15–30, and >30 m) and diameter at breast height (DBH; 0.3–0.6, 0.6–1, and >1 m).

The vegetation assemblage at each sampling point was characterized at two spatial scales: 100 m<sup>2</sup> and 500 cm<sup>2</sup>. At the larger scale, we established a circular plot of 5.64 m radius, centered on the marked sampling point. We documented the overall percent cover of rooted vegetation in the plot, using the cover classes 0, 1–25, 26–75, and >75%. We also recorded the dominance for each

<sup>1</sup> July 2005 porewater salinity and substrate data were lost for most VT, LE, and HE points in North region, and recollected on 9 August. Due to time constraints, these data were not collected for EG points in North and Central regions until 18 August.

species in the plot (<25, 25–50, or >50% of vegetation present). At the smaller scale, we placed a 12.6-cm radius hoop at four distances and orientations from the plot center: 1 m at 90° from north and 4 m at 30, 150, and 270°. Within each subsample, we counted the number of shoots for emergent species and estimated the percent cover for algae, wrack, wood, or other non-emergent items. Cover classes included <1, 1–5, 6–25, 26–50, 51–75, 76–95, and >95%.

Non-native plant species of concern at PSB included *S. anglica* and *Z. japonica*. In the emergent wetland and diked habitats, *S. anglica* clones were tallied by diameter class within 1 m of the three 50-m transects. In the tidal flat habitats, vegetation was sufficiently sparse to allow detection of *S. anglica* from a greater distance, and here we tallied clones by diameter class within 25 m of the plot center (1,964 m<sup>2</sup> total area). Diameter classes included <0.1, 0.1–0.5, 0.5–1, and >1 m. For *Z. japonica*, we estimated the percentage of the 100-m<sup>2</sup> plot colonized, using the classes 0, <1, 1–5, 6–25, 26–50, 51–75, and >75%, and then recorded a representative shoot density within 500 cm<sup>2</sup>. We collected benthic invertebrates at 42 sampling points: 3 in DW, 3 in EG, and 9 in each of the remaining habitats except BS. Invertebrates were collected using a 7-cm diameter corer plunged 10 cm into the sediment. Samples were placed into labeled Nalgene jars, kept on ice up to 24 hours, and then washed and separated using tap water. Contents retained in a 500-µm sieve were placed in labeled jars, fixed with 5% buffered formalin, and stained with Rose Bengal. Samples were transferred to a contractor, who sorted, counted, and identified contents to the finest taxonomic resolution possible under an illuminated dissecting microscope.

### **Data Processing and Analysis**

Habitat boundaries were refined in ArcGIS to correspond with 2004 and 2005 field observations. Typically, refinement involved visually inspecting the aerial photographs around sampling points that differed in predicted versus observed habitat, and then adjusting the polygon boundary such that points fell within the appropriate habitat type. We calculated to total area for each of these refined habitat polygons.

As a first step toward understanding how the estuary has been impacted by hydrologic modifications in the river delta, we structured our analysis to make comparisons across the landscape. Sea dikes not only exclude tidal and river flows from a majority of the historical estuary, but also alter hydrologic, geomorphic, and sedimentary processes within the existing estuary (Hood 2004). This is thought to be particularly true for The Nature Conservancy's dike, which is situated north of the river mouth and extends farther seaward than other dikes. Thus, we divided the estuary into three geographic regions relative to our dike (North, Central, and South; Fig. 3b) and designated each sampling point to a region using a spatial join in ArcGIS.

Physical and biological data were processed to generate standardized metrics for statistical comparisons. Surface elevation data were triangulated by the equipment retailer to generate elevations relative to the North American Vertical Datum (NAVD88). For channels, LWD, *S. anglica*, and other vegetation, we converted each size, angle, and cover class to its median value. We estimated channel cross-sectional area (CSA) utilizing median width, depth, and bank angles in the geometric equation for trapezoid area.<sup>2</sup> CSAs for some channels were adjusted to triangular or rectangular geometries if the trapezoid calculation was inappropriate given the coarse input data.

<sup>2</sup> The geometric equation for trapezoid area is  $(b_1 + b_2) h / 2$ , where  $b_1$  represents the recorded bankfull channel width,  $b_2$  the width of the channel bed, and  $h$  the channel depth. We computed  $b_2$  by subtracting from  $b_1$  the horizontal distances ( $d_1$  and  $d_2$ ) encompassed by the channel banks;  $d_1$  and  $d_2$  were calculated using properties of right triangles:  $h * \tan[(90 - \theta) * \pi/180]$ , where  $\theta$  equals a recorded bank angle in degrees.

We estimated LWD volume from median length and DBH. Areal cover of *S. anglica* clones was estimated from median diameter, using the equation for circular area. We normalized channel, LWD, and *S. anglica* counts for each sampling point to 100 m, 1000 m<sup>2</sup>, and 250 m<sup>2</sup>, respectively, allowing for density comparisons across habitats. We summed shoot counts from the four 500-cm<sup>2</sup> vegetation subsamples to give species densities per 0.20 m<sup>2</sup>; we normalized invertebrate densities to 100 cm<sup>2</sup> of surface area, given standard 10 cm sampling depth. We calculated two measures of diversity for vegetation and invertebrates: richness and Shannon-Wiener diversity. Vegetation richness was determined from the 100-m<sup>2</sup> plots, whereas diversity was computed from the four subsamples.

Physical and biological metrics for 2004 and 2005 were compared among habitats using ANOVA followed by pairwise comparisons, with Bonferroni's correction to the p-value ( $\alpha = 0.05$  for physical and vegetation metrics,  $\alpha = 0.10$  for invertebrates). To test for regional differences, we excluded diked habitats (plus EG for invertebrates) and compared metrics by intertidal habitats and regions using full factorial ANOVA with Bonferroni's pairwise comparisons. When a significant interaction was found between habitat and region, data were split by intertidal habitat and compared among regions (ANOVA followed by Bonferroni's pairwise comparisons,  $\alpha = 0.10$ ). Data were generally log or square root transformed to reduce skewness and kurtosis prior to analysis; an exception was overall percent cover of vegetation, which was arcsine square root transformed. Densities of common plant species, *Z. japonica* percent colonization, and invertebrate class densities were compared among habitats ( $\alpha = 0.05$ ), and regions within habitats ( $\alpha = 0.10$ ), using Kruskal-Wallis non-parametric tests followed by Mann-Whitney non-parametric pairwise comparisons, with Bonferroni's adjustment to the p-value. Frequencies of substrate classes were qualitatively compared among habitats and regions.

### 13.15 Salinity and Temperature Profiles Standard Operating Procedures

The Nature Conservancy

*Suggested citation: The Nature Conservancy. 2011. Salinity and temperature profile standard operating procedures. Unpublished protocols. The Nature Conservancy, Skagit River Office, Mt.Vernon, WA*

*Disclaimer: Any use of trade, product, or firm names in this publication is for descriptive purposes only and does not imply endorsement by The Nature Conservancy.*

#### **Purpose/Objective**

Salinity and temperature profiles will be conducted throughout the estuary during different tide series, seasons, and freshwater flows to assist with testing and calibration of models. Three to four transects of five to seven monitoring stations each will be established in a roughly north-to-south orientation at quarter- to half-mile intervals from the dike front. Salinity and temperature profiles will be conducted at these and the in-situ monitoring stations at least once a month throughout the year.

#### **Methods**

Salinity and temperature readings are taken at the surface and bottom and approximately every 50 cm of the water column at each monitoring station.

#### **Equipment**

- A conductivity-temperature-depth (CTD) logger would be ideal for collecting water column profiles. However, a salinometer with depths marked on the probe cable could likely suffice. A YSI Professional Plus handheld multiparameter instrument could also be used and would include measurements for dissolved oxygen, conductivity, specific conductance, salinity, resistivity, total dissolved solids (TDS), pH, ORP, pH/ORP combination, ammonium (ammonia), nitrate, chloride and temperature (<http://www.ysi.com/productsdetail.php?Professional-Plus-18>)
- A boat capable of traveling in shallow water will be essential.

#### **Status and remaining questions**

- Details regarding the exact installation locations, methodology, and equipment should be determined by an experienced and qualified contractor after surveying on-site conditions.
- Other water quality parameters, such as pH and turbidity, could potentially be monitored at the same locations (continuous and/or profile stations) and potentially with the same data logger, depending on the equipment purchased.
- A new elevation benchmark will need to be installed at the preserve, and ideally tied into a NOAA gage.
- Many questions remain concerning the collection of salinity and temperature profile data, as there was not sufficient time for adequate research. Charles Simentstad suggested that an optimal scenario would take profiles at fixed stations during high and low slack tides, spring and neap tide series, and periods of high, fluctuating, and low freshwater flow. How the low tide stations might be arranged and whether this approach is feasible will need to be determined.
- Zhaoqing Yang and Charles Simenstad were consulted regarding this monitoring design. Other individuals, from institutions such as Philip Williams and Associates, the Wetlands Regional Monitoring Program, and the Puget Sound Nearshore Partnership, may have additional insights and recommendations.

### 13.16 Potential Collaborators

1. Ducks Unlimited / WDFW – may have some interest in monitoring for the Leque Island restoration project. Contact: John Axford (engineer), (360) 885-2011 x33, [jaxford@ducks.org](mailto:jaxford@ducks.org); Dan Golner (project manager), (253) 853-6936, [dgolner@ducks.org](mailto:dgolner@ducks.org)
2. Fish and Wildlife Service conducts mid-winter aerial waterfowl surveys each winter
3. Snohomish Co. Surface Water Management – conduct ambient water quality monitoring each month, recording multiple parameters. Contact: Steve Britsch, (425) 388-3464 x4668, [sbritsch@snoco.org](mailto:sbritsch@snoco.org)
4. Stillaguamish Tribe – have been collecting salinity, conductivity, temperature, dissolved oxygen, and fecal coliform data on a monthly basis at approximately 11 sites in PSB since 1998. Also monitoring water quality in the river. Contact: Jody Brown, (360) 547-2686, [jbrown@stillaguamish.nsn.us](mailto:jbrown@stillaguamish.nsn.us)
5. U. S. Geological Survey – Western Ecological Research Center leads monitoring of Nisqually tidal marsh restoration. Coastal & Marine Geology monitors geomorphology of Skagit Bay and involved with ecological monitoring of the Nisqually estuary restoration project.
6. Warm Beach Christian Camp and Conference Center – monitoring dike pond and tributaries water quality. Contact: Kelly Wynn (contractor), Water and Wastewater Services, (360) 466-4443 x201, [kellyw@wwsvc.com](mailto:kellyw@wwsvc.com)
7. Washington Department of Ecology – conduct surface water quality monitoring required by the NPDES permit for Twin City Foods wastewater treatment facility (fecal coliform and other parameters). Also monitor marine water quality near Kayak Point for PSAMP. Contact: Lori LeVander (NPDES permit manager), [llev461@ecy.wa.gov](mailto:llev461@ecy.wa.gov); Dustin Billheimer (GIS technician)
8. Western Washington University – monitoring sediment dynamics in Skagit, Padilla, and Willapa bays. May have graduate students to assist with equipment installation and monitoring. Contact: John Rybczyk, (360) 650-2081 office, (360) 223-5806 cell, [john.rybczyk@wwu.edu](mailto:john.rybczyk@wwu.edu)